

# Installation/Owners Manual

## **PATRIOT I** Single Swing Gate Operator

## **PATRIOT II** Dual Swing Gate Operator

**MADE-IN-THE USA**



**Heavy Duty**

**Battery Powered**

**Solar or AC Charged**

# **WARNING**

## **TO REDUCE THE RISK OF INJURY OR DEATH**

1. **READ AND FOLLOW ALL INSTRUCTIONS**
2. Study the entire Safety Section paying particularly close attention to the entrapment zones and be aware of these areas not only during use but also during any adjustments to the unit.
3. Do not attempt to enter the gate area while the gate is moving. Wait until the gate comes to a complete stop.
4. Never let children operate or play with gate controls or any other activation device. Keep remote control away from children.
5. **DO NOT ALLOW CHILDREN TO PLAY IN THE AREA OF THE GATE.**
6. Do not allow anyone to ride on the gate.
7. Always keep people and objects away from the gate.
8. **NO ONE SHOULD CROSS THE PATH OF A MOVING GATE.**
9. Operate the gate only when it is fully visible, free of persons or obstructions, and properly adjusted.
10. Do not attempt to “beat the gate” while the gate is opening or closing. This is extremely dangerous.
11. Test gate operator monthly. The gate must stop and reverse directions upon contacting a rigid object or when the secondary entrapment device is activated.
12. After all adjustments have been made to the sensitivity (current sense) circuit, secondary entrapment devices and all other external devices installed, the safety devices must be checked again. Failure to adjust and retest the gate operator can increase the risk of injury or death.
13. Verify that the emergency release (manual release) pin can be easily removed.
14. **KEEP GATES PROPERLY MAINTAINED.** Tighten all bolts and grease hinges and pivot points.
15. **THE ENTRANCE IS TO BE USED BY VEHICLES ONLY.** Pedestrians must use a separate entrance.
16. All safety features required by UL 325 are incorporated in the capabilities of all USAutomatic control boards and should be utilized, including but not limited to, safety edges, photo electric eyes, reverse sensing.
17. Test the current sense feature and all safety devices regularly to insure correct operation.
18. The USAutomatic battery charger is designed to operate with a recommended +12 VDC, sealed maintenance free type Group U-1 battery. 30 amp hour minimum.
19. All control stations should be located at least 6 feet from any moving part of the gate or operator.
20. Do not ever install any control device where a user will be tempted to reach through the gate or fence to activate a gate.
21. Do not attempt to completely seal the control box. Battery needs some air flow.
22. **SAVE THESE INSTRUCTIONS!!**



# **PATRIOT** Series **AUTOMATIC GATE OPERATORS**

The Patriot Gate Operator is intended to be installed on vehicular Class I, II, III or IV gates as defined by UL 325, (the standard that regulates gate operator safety, as established and made effective March 14, 2003, by Underwriters Laboratories, Inc.). Maximum gate load not to exceed 650 pounds and 16 feet in length.

The Patriot control board was designed with a current sense safety feature. We strongly recommend other safety devices such as photo eyes, contact sensors etc... to make each particular installation as safe as possible and reduce the risk of personal injury and/or property damage.

## **PLEASE READ CAREFULLY AND UNDERSTAND THE SAFETY SECTION OF THIS MANUAL.**

The Patriot system design and the accessories recommended are all Solar Friendly meaning that they require the least amount of energy possible to perform the job they were designed to do. The solar option allows you to install the gate operator in remote areas or in applications where you prefer to be solar charged. Solar charging provides additional isolation from lightning that might damage the unit via the AC power needed for the transformer.

### **BATTERY REQUIRED FOR OPERATION** *(Battery not included)*

#### **Recommended battery type:**

Battery 12-volt, Group U-1; sealed (maintenance free); 30 amp hour minimum.  
Using a smaller amp hour battery may cause damage to the charging system.  
The wiring harness has two 1/4" ring terminals to connect to battery posts.

**CAUTION: Do not install wet cell battery into control box; this type of battery usually has removable caps used for service and will vent into control box.**

The battery is charged using the 120V AC Powered Transformer (PN #520004) **OR** the Patriot Solar Panel kit (PN 520025). Typically only one panel will be required. The Patriot gate operator is capable of a high number of cycles per day. For information on what you can expect from a solar charged system see the solar charging section of this manual. (page 64) Accessories that are added to your gate operator must be solar friendly accessories and they will be identified as such. Visit [www.usautomatic.com](http://www.usautomatic.com) for more information.

## **PLEASE READ THE ENTIRE MANUAL CAREFULLY PRIOR TO INSTALLATION.**

© USAutomatic, LTD, 2015 rev. A

All rights reserved. No part of this manual may be reproduced by any means without the expressed written consent of the publisher.

USAutomatic Part # 720001



# TABLE OF CONTENTS

## INTRODUCTION

Safety Information .....	3
Patriot Parts Inventory .....	4
Patriot Hardware Inventory .....	5
General Tool Requirements .....	6

## PREPARATION AND OVERVIEW

Gate Qualifications/Applications .....	7
Proper Gate Design .....	8

## INSTALLATION STEPS

1. Mounting Site Review .....	9
2. Determine Opening Method (pull to open or push to open) .....	10
3. Determine Horizontal Mounting Location .....	11
4. Determine Best Method for Actuator Mounting Brackets - Pull to Open .....	12
Determine Best Method for Actuator Mounting Brackets - Push to Open .....	13
Determine Best Method for Actuator Mounting Brackets - Columns .....	14
5. Mount Support Bracket .....	15
6. Installing Actuator Mounting Tube - Pull to Open .....	16
Installing Actuator Mounting Tube - Push to Open .....	17
7. Installing Linear Actuator to Actuator Mounting Bracket .....	18
8. Install Gate Bracket to Linear Actuator .....	19
9. Install Gate Bracket to Gate .....	19
10. Install Patriot Control Box .....	20
11. Install Patriot Control Board .....	21
12. Installing Receiver and Smart Charger / Charge Controller .....	21
13. Install Linear Actuator Cable .....	22
Splicing Linear Actuator Cable Cable and Dual Gate Cable.....	22
14. Install Battery .....	23
15. Install Smart Charger / Charge Controller Power Source (AC or Solar) .....	24
16. Connect Power Source to Smart Charger / Charge Controller .....	26
17. Smart Charger / Charge Controller Operation Check .....	26
18. Patriot Control Board Information .....	27-31
19. Control Board Dipswitch Setting Verification.....	32
20. Gate Delay Feature .....	32
21. Optional Soft Stop for Retract or Extend Position .....	32
22. Connect Linear Actuator Cable to Control Board .....	34
23. Operating Gate For The First Time .....	34
24. Making Final Adjustments (Retract and Extend Limits and Sensitivity) .....	36
25. Programming Transmitter and Receiver .....	37
26. Install Safety Signs .....	38
27. Manual Release .....	38

## ENTRAPMENT ZONES..... 39

## PERIODIC SERVICE..... 39

## ACCESSORIES..... 40-47

## TROUBLESHOOTING..... 48-62

## APPENDIX

A. Gate Cycles per day AC or Solar Charged.....	64
B. Extending Charge Device Location .....	65
C. Charge Controller .....	66

## WARRANTY..... 68



# SAFETY INSTALLATION INFORMATION

USAutomatic gate operators are certified to UL325 Vehicular Class I, II, III and IV swing gate standards. UL325 identifies four different classes of gate operators. These classes are listed below:

**Class I :** Residential vehicular gate operator- vehicular gate operator (or system) intended for use in a home of one to four single family dwellings or a garage or parking area associated therewith.

**Class II :** Commercial/General access vehicular gate operator- vehicular gate operator (or system) intended for use in a commercial location or building such as multi-family housing unit (five or more single family units), hotel garages, retail, or other buildings servicing the general public.

**Class III :** Industrial/Limited access vehicular gate operator- vehicular gate operator (or system) intended for use in an industrial location or building such as a factory or loading dock area or other locations not intended to serve the general public.

**Class IV :** Restricted Access vehicular gate operator- vehicular gate operator (or system) intended for use in a guarded industrial location or building such as an airport security area or other restricted access locations not servicing the general public, in which unauthorized access is prevented via supervision by security personnel.

## INSTALLATION

### Install the gate operator when:

- Operator is appropriate for the construction of the gate and usage class is correct for the installation.
- All exposed pinch points are eliminated or guarded.
- The gate is a vehicle gate. Pedestrians must be supplied with a separate access opening.
- The gate is installed in a location where enough space is supplied between adjacent structures and the gate that when opening or closing the chance of entrapment is reduced.
- The gate does not swing into public access areas.
- The gate is properly installed and swings freely in both directions. Do not over adjust the sensitivity adjustment to compensate for an improper gate installation.
- All controls are located at least six feet away from the gate to eliminate the chance of the person operating the gate from coming in contact with the moving gate. Do not install external buttons, which can be used to operate the gate within the reach of children.
- Safety Signs are installed, one on each side of the gate and visible in the gate area.
- All hard wired sensors used for secondary entrapment safety devices and their wiring are installed in a manner which protects them from mechanical damage.
- All wireless sensors used for secondary entrapment safety devices are located so that the signal from the transmitter to the receiver is not interfered with by adjacent structures. All exposed wiring must also be protected from mechanical damage.

## SECONDARY ENTRAPMENT DEVICES

**USAutomatic designs all control boards with secondary entrapment device inputs. USAutomatic recommends that UL325 listed secondary safety devices be installed with all installations.**

USAutomatic recommends that these devices be connected after proper gate installation and operation has been verified. Then connect one device at a time to verify proper operation before installing the next device. Ensure that power is disconnected from the control board prior to wiring any accessory. Review Entrapment Zones on Page 39.



# PARTS INVENTORY

## All Operators include:

### Cabinet with Control Board

Part # 600020 Cabinet  
 Part # 602020 Cover  
 Part # 500001 Control Board



### Patriot Actuator

Part # 510001  
*Patriot I - 1 per*  
*Patriot II - 2 per*



### Dual Gate Actuator Extension Cable 40'

Part # 630020  
*Patriot II ONLY*



### Charge Controller

Part # 520006



### AC Charging Transformer

Part # 520004  
*with Patriot AC Models*



### Solar Charging Kit

Part # 520025  
*with Patriot Solar Models*

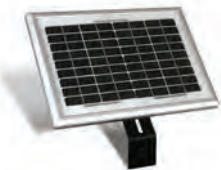

### Safety Signs

Part # 601020  
 2 per



## Operators purchased with LCR Radio Controls include:

### 2 Button Transmitter

Part # 030210  
 2 per



### LCR Radio Receiver W/Harness

Part # 030205



### Coax Antenna Cable and Bracket

Part # 030013



### Antenna

Part # 030208



## Optional Accessories & LCR Items:

*See accessories section (pages 40-47) for complete list and descriptions*

**4 Button Transmitter** - Part # 030212

**Push to Operate Button** - Part # 030215

**Wireless Keypad - Plastic** - Part # 050500

**Wireless Keypad - Metal** - Part # 050550

**Garage Door Receiver** - Part # 030214

**12/24 Receiver** - Part # 030207

**Electric Gate Lock** - Part # 070510

**7 Day Timer** - Part # 550015

**Exit Sensor** - #070305

**Photo Eye** - #550010

# HARDWARE INVENTORY

## BRACKETS

### Support Bracket

Part # 610425  
*Patriot I - 1 per*  
*Patriot II - 2 per*



### Mounting Tube

Part # 610102  
*Patriot I - 1 per*  
*Patriot II - 2 per*



### Gate Bracket

Part # 610107  
*Patriot I - 1 per*  
*Patriot II - 2 per*



### Manual Release Pin

Part # 620010  
*Patriot I - 1 per*  
*Patriot II - 2 per*



### Manual Release Pin Clip

Part # 620011  
*Patriot I - 1 per*  
*Patriot II - 2 per*



### Bronze Bushing

Part # 610530  
*Patriot I - 2 per*  
*Patriot II - 4 per*



### Nylon Washers

Part # 610529  
*Patriot I - 2 per*  
*Patriot II - 4 per*



### 3/8" Bolt

Part # 610512  
*Patriot I - 1 per*  
*Patriot II - 2 per*



### 3/8" SAE Flat Washers

Part #610516  
*Patriot I - 2 per*  
*Patriot II - 4 per*



### 3/8 inch Lock Nuts

Part # 610518  
*Patriot I - 1 per*  
*Patriot II - 2 per*



### 1" Plastic Standoff

Part #620008  
*Patriot I - 7 per*  
*Patriot II - 8 per*



### Cable Clamp

Part # 650020  
*Patriot I - 1 per*  
*Patriot II - 2 per*



### Secondary Entrapment Siren

Part # 530010  
*1 per*



### Charge Control Harness

Part # 630040  
*1 per*



### Screwdriver

Part # 610006  
*1 per*



# GENERAL TOOL REQUIREMENTS

- SAE Standard wrenches & sockets
- Nut driver
- Level and tape measure
- Pliers
- Wire Cutters/Strippers
- Welder
- Drill and bits
- Drill adapter for socket attachment
- Hack saw

Welding is the recommended method of securing the linear actuator mounts to the gate and hinge post. Bolt on brackets require frequent service to keep tight. They must be very securely attached (i.e. carriage bolts with lock nuts and washers). Lag type bolts are not recommended. Loose or unstable linear actuator mounts will result in improper operation.

## IMPORTANT CAUTIONS:

- A. Do not perform any welding with the actuator cable plugged into the control board or the battery connected. Serious damage to the control board and/or battery may occur if attempted.
- B. Do not attempt to hold control box and drill mounting holes with components installed. This could damage the components.
- C. Always disconnect the battery power from the control board using the quick connect harness prior to wiring any devices to the control board.
- D. Do not test or operate without actuator securely attached to the gate. Serious damage to the actuator limit switch assembly may occur if attempted.



# PREPARATION AND OVERVIEW

## GATE QUALIFICATIONS/APPLICATIONS

This gate operator is rated for vehicular class I, II, III, or IV swing gates up to 16 feet in length and up to 650 pounds in weight, as defined by UL-325. If your gate exceeds either one of these limits, please consult a qualified technician or the factory for application questions and advice. (Example: Convert one 20' gate into two 10' gates and use a dual gate operator.)

**Note:** *The total gate opening normally cannot exceed 120 degrees.  
Consult a service technician or the factory if greater opening is required.*

The Patriot Gate Operator is recommended for Gates that meet the following descriptions:



**Ornamental Iron**  
16 feet max length  
Max weight 650 lbs.



**Farm Gate**  
20 feet max length  
Max weight 300 lbs.



**Ranch Gate**  
16 feet max length  
Max weight 650 lbs.



**Chain Link Gate**  
16 feet max length  
Max weight 650 lbs.

## PROPER GATE DESIGN

### IMPORTANT- A GATE OPERATOR CANNOT OVERCOME A POORLY DESIGNED GATE.

Since the gate is a major component of the system, great care and concern must be given to the gate design. USAutomatic, LTD is not responsible for any damage to a gate on which the gate operator is installed. A poorly installed or misadjusted gate could be damaged. It is the responsibility of the installer to verify proper gate installation prior to operator installation. As a general rule, a gate, which is to be automatically operated, must be stronger and smoother than one operated manually.

- Does the gate swing smoothly without binds or excessive resistance?
- Swing gates should swing level and plumb to prevent the operator from having to lift the gate open or closed.
- Swing gates should not require a wheel to support them. Wheels create drag, which will cause operator problems. A wheel is generally a sign of a weak hinge system or a weak gate frame.
- Is the gate frame of substantial strength without excessive weight?
- Will the frame withstand normal wind load conditions without sway or vibration?
- Will the gate close correctly without being hand-guided or lifted to close?
- Are the hinges suited for an automatic gate operator? We recommend bearing type hinges to reduce friction drag.
- Will a reinforcement brace be required to attach the linear actuator to the gate or does a suitable cross member exist in the gate design? See pg 11 for examples.

If any of these problems exist, they must be corrected to achieve a reliable automatic gate system.

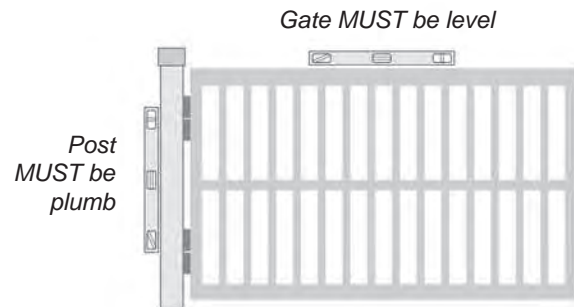

Gate should not require a wheel for support.



Gate should not be unlevel due to weak frame.



Gate should not be unlevel due to unlevel post.

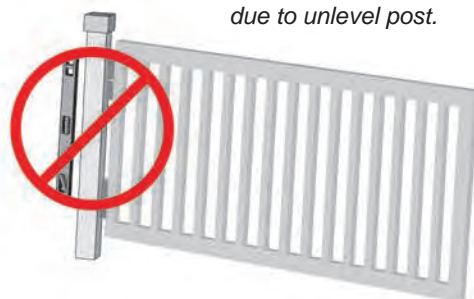

# I

## Mounting Site Review

Review the following items prior to installation and predetermine the solution to any problems which may exist:

1. Does sufficient space exist for mounting and future servicing of the operator and control box?
2. Which direction will the gate swing?
  - a. Will the gate operator pull the gate open to the inside (Pull to Open)?
  - b. Will the gate operator push the gate open to the outside (Push to Open)?  
(See Determine Opening Method Section pg 10)
3. Where and how will the actuator mounting brackets be secured to the hinge post and to the gate? (pgs 11-14)
4. How will the gate bracket be secured to the gate and will additional reinforcement be required? (pg 11)
5. Where will the control box be mounted to support the weight of the battery and other components and can it be located within 8 feet to prevent splicing of the linear actuator cable? (pg 20)
6. For AC Charged System - How far away is the 120 VAC receptacle for the transformer? Transformer is supplied with 12 feet of cable. If extension is needed use power source cable Extension Kit part #630038. See Power Source Cable Extension chart for identifying the wire size needed for the distance required. Transformer must be installed indoors or in a raintight enclosure. Transformer should not be exposed to moisture. (pg 24)
7. For Solar Charged System - Where will the solar panel mount so that optimum sunlight is received? Solar panel is provided with 15 feet of cable, If extension is needed use power source cable Extension Kit part #630038 or 75' Solar Extension part #520016. See Power Source Cable Extension chart for identifying the wire size needed for the distance required. Solar panel typically needs to be facing a South or Southwest direction. (pg 25)
8. How will accessory control wiring, if any, be brought to the control box? Knock outs are provided in control box bottom for conduit. (pg 20)
9. Have all safety concerns been addressed? See Safety Section pg 3 and Entrapment Zones on pg 39 for more information.



## 2 Determine Opening Method

(pull to open or push to open)

### Pull to Open Installation

This installation method is the most common where the gate swings into the property and the operator **pulls** the gate open.

EXTENDED (Gate Closed)

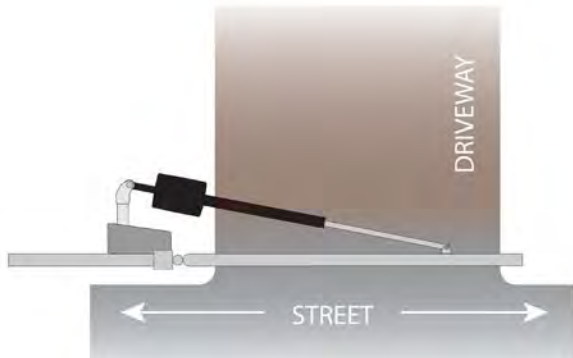

RETRACTED (Gate Open)

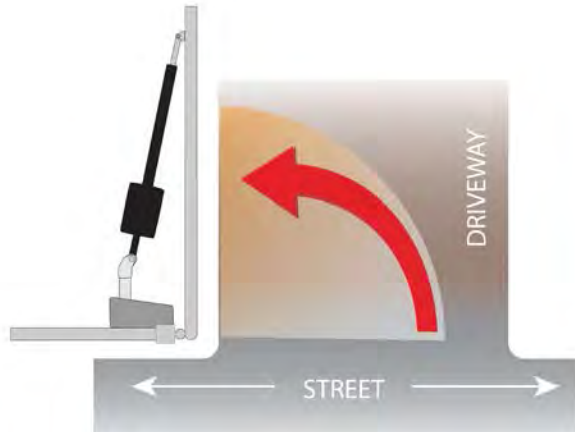

### Push to Open Installation

This installation method is commonly used where the drive slopes upward into the property and the operator **pushes** the gate open. The gate swings outward away from the property.

EXTENDED (Gate Open)

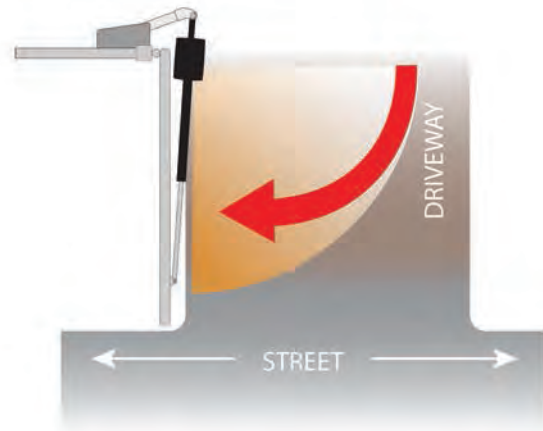

RETRACTED (Gate Closed)

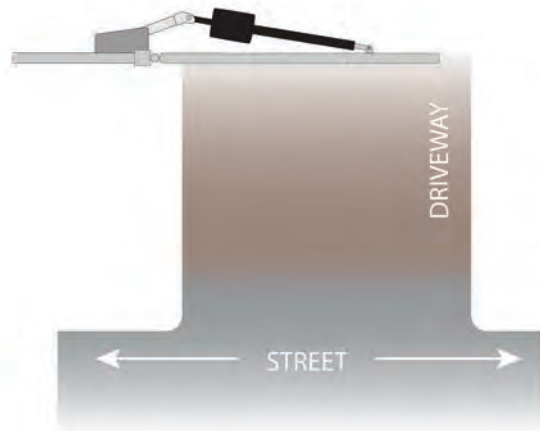

### 3 Determine Horizontal Mounting Location

Now that the type of installation (pull to open or push to open) has been determined, the vertical height position of the support bracket and actuator mounting tube must be determined. Refer to these examples to determine the mounting location of the gate bracket on the gate, which is needed to determine the location of the actuator mounting tube.

The actuator delivers force on the gate when operating. Aligning the actuator mounts with a horizontal gate frame member is the best choice. (as shown here)

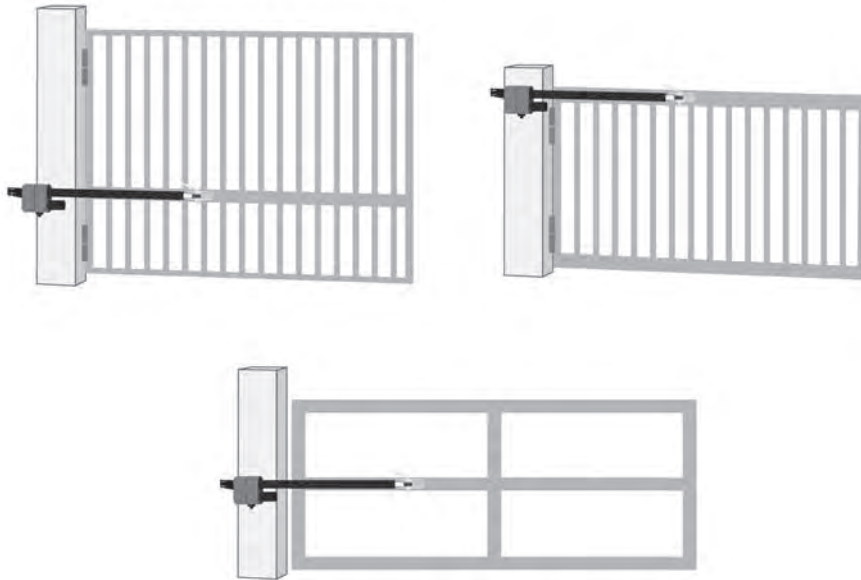

Installation of a horizontal brace may be necessary to prevent damage to vertical gate pickets.

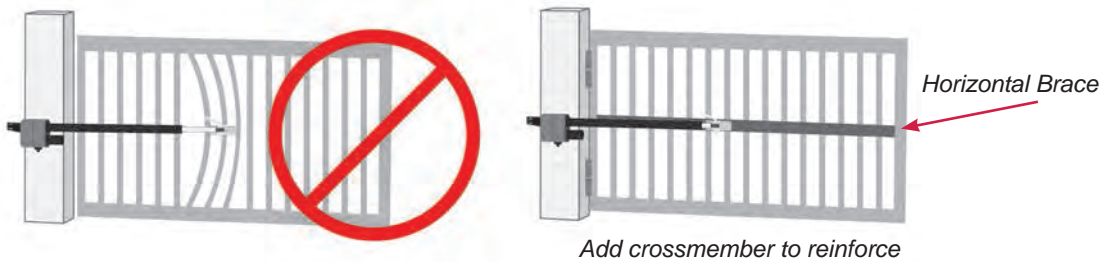

Avoid mounting actuator on bottom rail of gate. Unit will be more likely to be damaged by flooding and will be difficult to service and adjust.

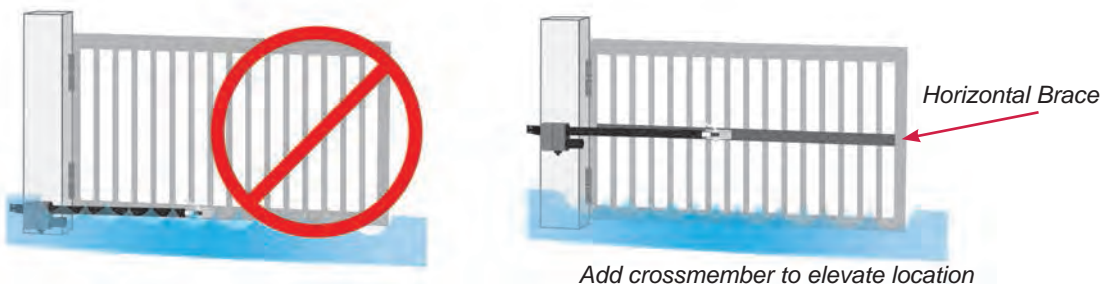

# 4a

## Determine Best Method for Actuator Mounting Brackets - PULL TO OPEN

Study the examples below and determine the best method for your gate. The examples below are for left hand installations. Reverse for right hand installations.

### Square Post

Actuator support bracket mounted horizontally on hinge post

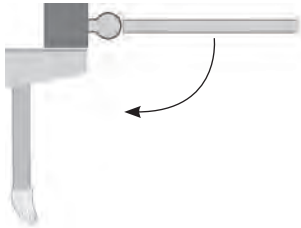

Actuator support bracket mounted horizontally on fence rail

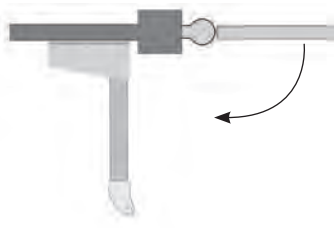

Actuator support bracket mounted vertically on hinge post

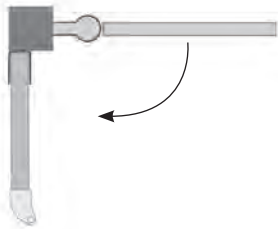

Actuator support bracket mounted vertically opposite hinge

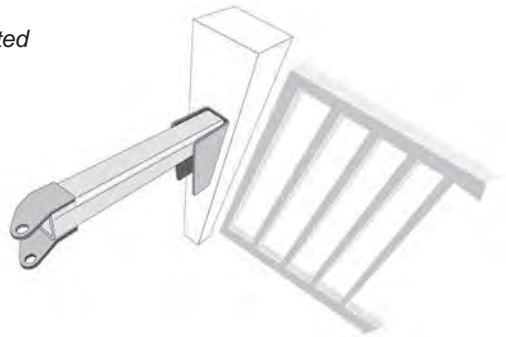
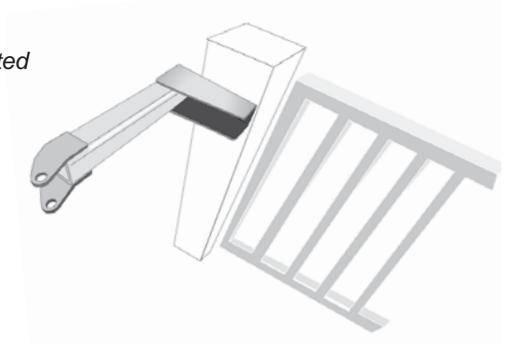
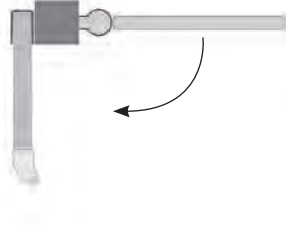

3D Example

### Round Post

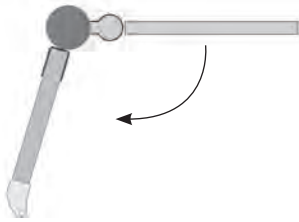

Actuator support bracket mounted vertically on hinge post

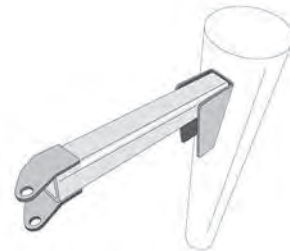

### Wood or Aluminum Post



Drill through mounted.

Drill through post and bracket. Use carriage bolts with back plate. (not included)

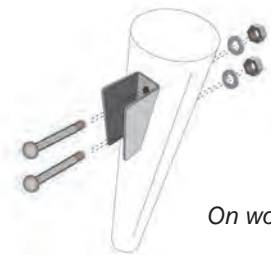

On wood post

## 4b Determine Best Method for Actuator Mounting Brackets - PUSH TO OPEN

Study the examples below and determine the best method for your gate. The examples below are for left hand installations. Reverse for right hand installations.

### Square Post



*Actuator support bracket mounted horizontally on hinge post*

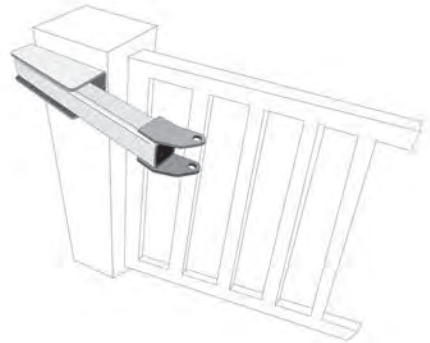

### Round Post

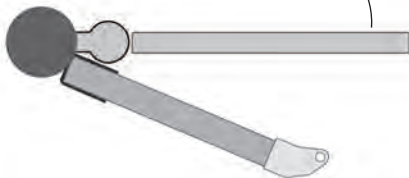

*Actuator support bracket mounted vertically on hinge post*

*3D Example*

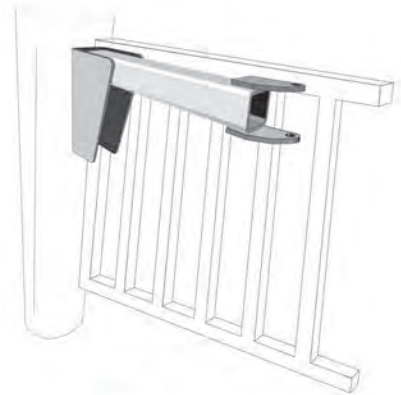

### Wood or Aluminum Post

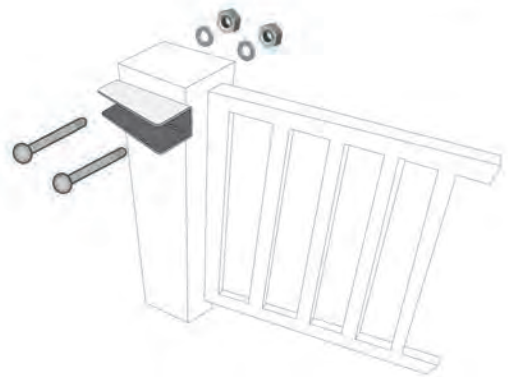
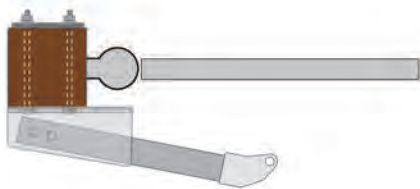

*Drill through mounted.*

*Drill through post and bracket.  
Use carriage bolts with back plate.  
(not included)*

# 4C Determine Best Method for Actuator Mounting Brackets - COLUMNS

Dimensions shown are for 90° - 95° opening.

## New Construction

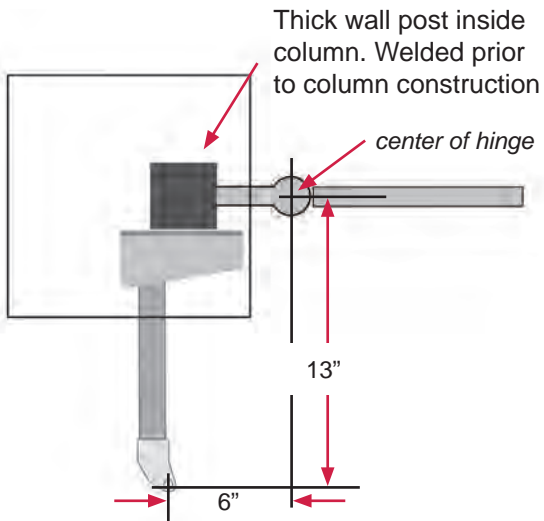

13" standard for 90°. Can be up to 16" if required for actuator to clear column.

## Existing Columns

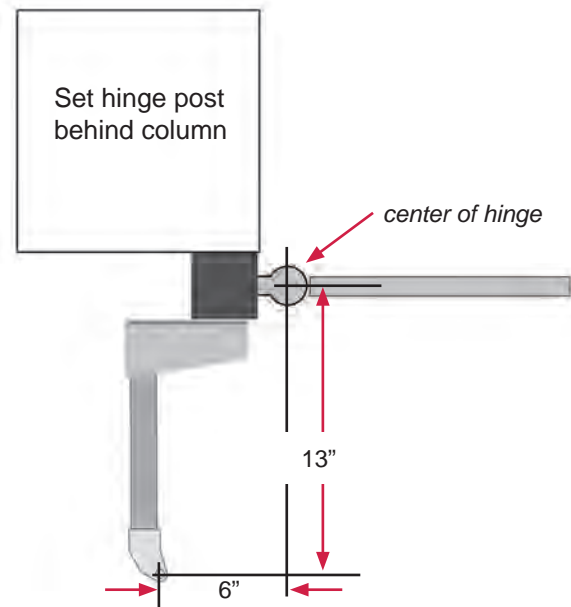

## Alternative Methods

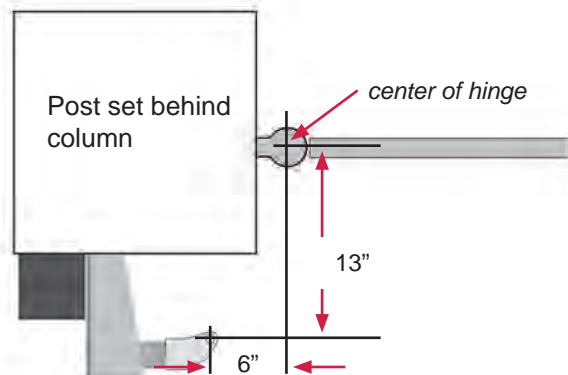
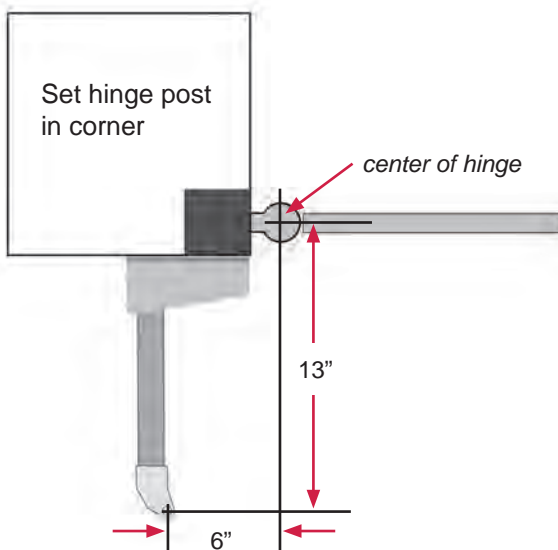



## 5 Mount Support Bracket

Now that you have determined the method and the vertical mounting location of the Actuator Support Bracket, mount the support bracket in alignment with predetermined horizontal frame member as per the following examples.

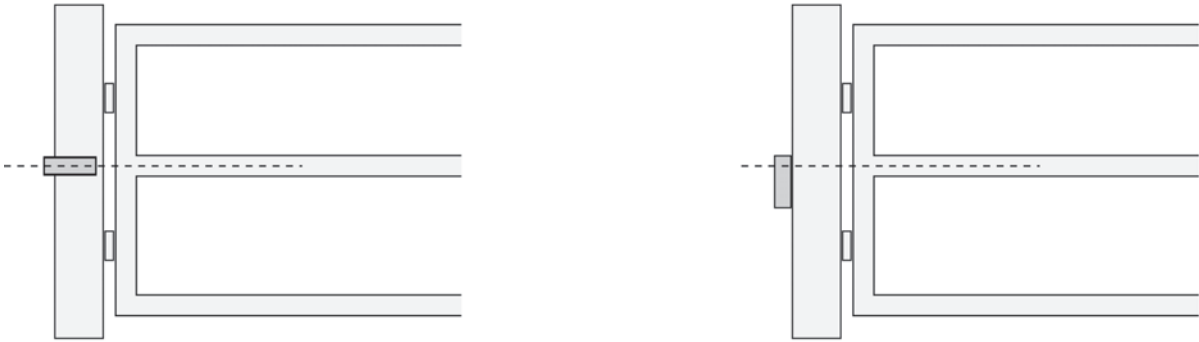

**Bracket must be level in all directions.**

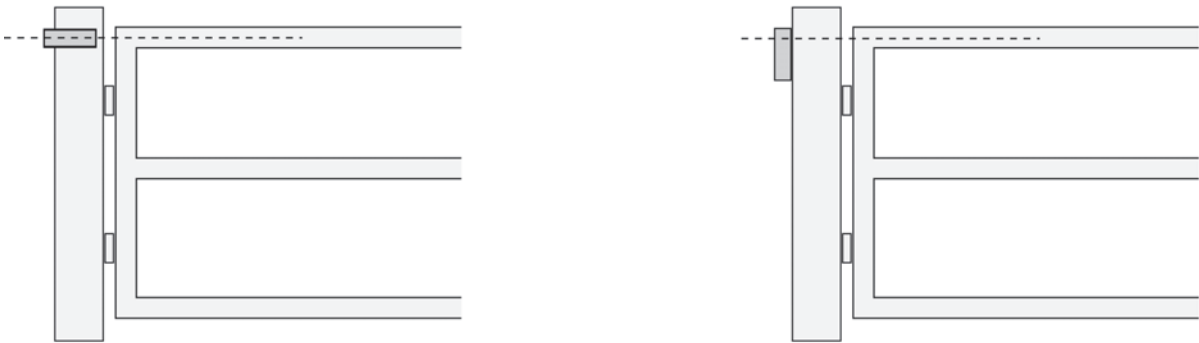

**DO NOT** mount support bracket in a manner that obstructs gate movement or creates a pinch point.

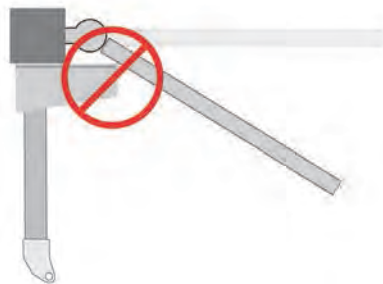

## 6a Install Actuator Mounting Tube - PULL TO OPEN

Cut Actuator Mount Tube to proper length. Weld to support bracket.  
 (See table below for desired dimensions.)

The actuator mounting tube will need to be cut so that the  $\frac{3}{8}$ " hole location matches the dimensions for a pull to open system.

Before welding in place, ensure the actuator mounting tube is level in all directions and the  $\frac{3}{8}$ " pivot hole location on actuator mounting tube is at proper point per the dimension chart for the type of installation being performed.

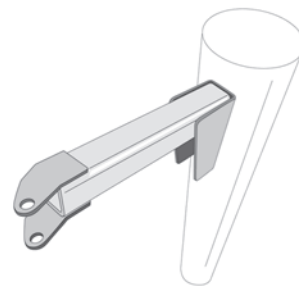
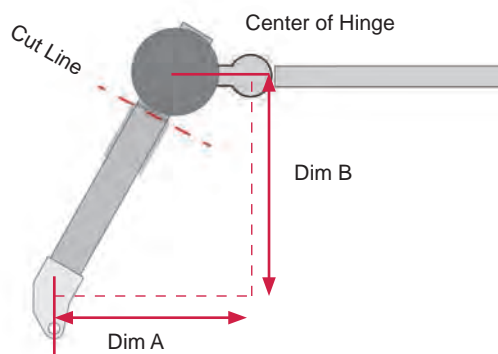
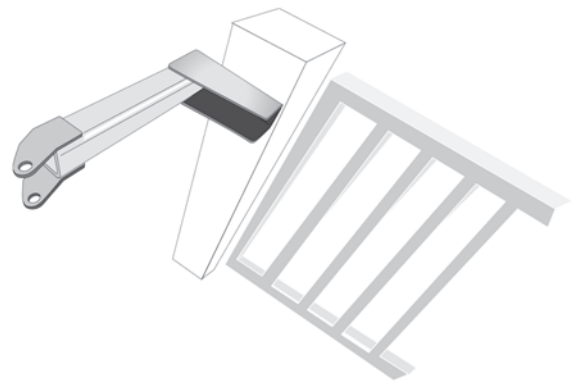
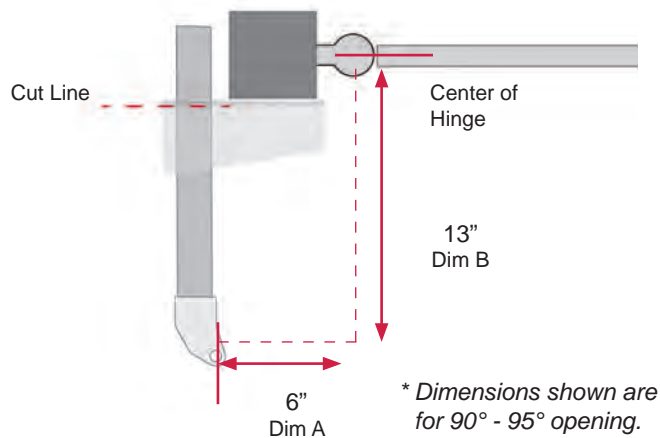

PULL TO OPEN - Actuator Hinge Mounting Tube Installation Dimensions		
Gate opening in degrees	Dimension A	Dimension B
90 degree opening	6"	13"
100 degree opening	7 ½"	12"
110 degree opening	9"	10 ½"
120 degree opening	11"	8"

## 6b Install Actuator Mounting Tube - PUSH TO OPEN

Cut Actuator Mount Tube to proper length. Weld to support bracket.  
 (See table below for desired dimensions.)

The actuator mounting tube will need to be cut so that the  $\frac{3}{8}$ " hole location matches the dimensions for a push to open system.

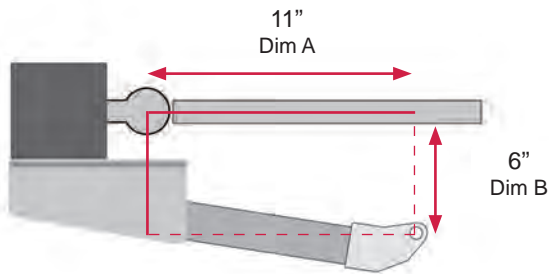

\* Dimensions shown are for 90° - 95° opening.

Before welding in place, ensure the actuator mounting tube is level in all directions and  $\frac{3}{8}$ " pivot hole location on actuator mounting tube is at proper point per the dimension chart for the type of installation being performed.

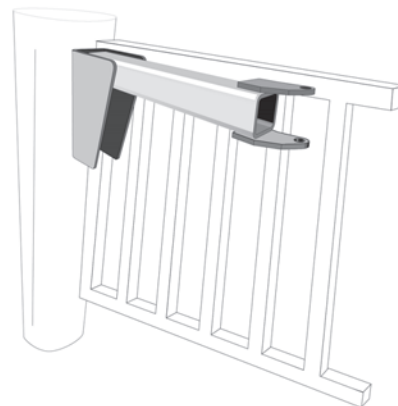
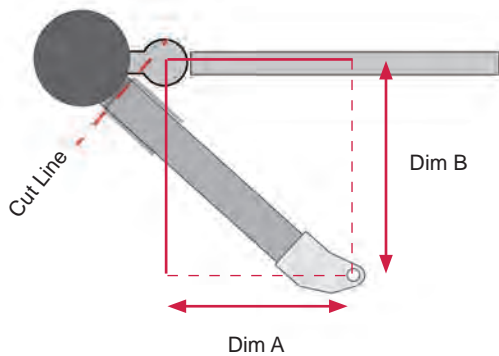
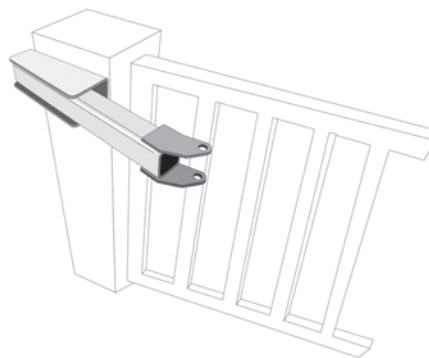

PUSH TO OPEN - Actuator Hinge Mounting Tube Installation Dimensions		
Gate opening in degrees	Dimension A	Dimension B
90 degree opening	11"	6"
100 degree opening	13"	6"
110 degree opening	14.5"	6"

# 7

## Install Linear Actuator to Actuator Mounting Bracket

The linear actuator should be mounted to the actuator mounting bracket using the provided hardware. Assemble as shown below. Tighten lock nut securely.

**Note:** The linear actuator may be installed UPSIDE down to facilitate limit adjustments at this point. Then after all adjustments have been made, install linear actuator correctly with cable pointing toward the ground. **Failure to do so will allow water to enter the rear housing and damage the limit assembly.**

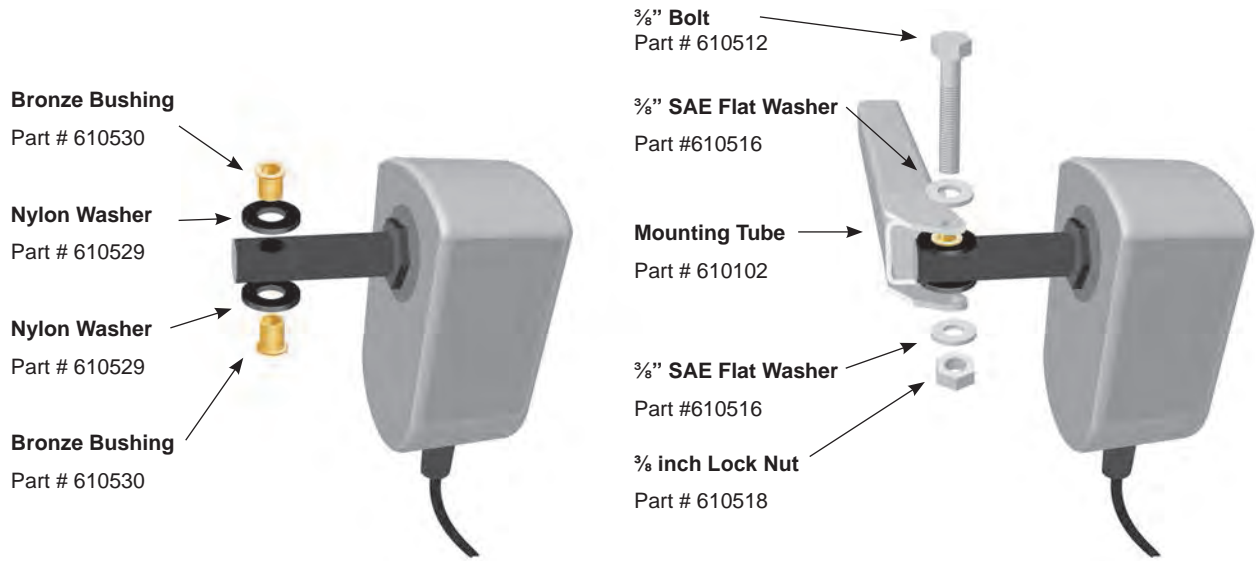

## 8 Install Gate Bracket to Linear Actuator

Install gate bracket and manual release pin to linear actuator as shown.

**DO NOT** operate the actuator before performing all installation steps. There is normally no need to extend the actuator before all installation steps are complete. If you must operate the actuator, ensure that the extension screw does not rotate while operating to avoid possible actuator limit assembly damage.



## 9 Install Gate Bracket to Gate

**(PULL TO OPEN INSTALLATION ONLY)**

The linear actuator was shipped from the factory set to the fully retracted position. The steps below will determine where the gate bracket is to be installed on the gate.

1. Swing gate to the fully open position.
2. Swing linear actuator around in a level position to meet the fully open gate. The contact point is where the gate bracket should be installed on the gate.
3. Weld or bolt the gate bracket to the gate.



**(PUSH TO OPEN INSTALLATION ONLY)**

The linear actuator was shipped from the factory set to the fully retracted position. The steps below will determine where the gate bracket is to be installed on the gate.

1. Swing gate to the fully closed position.
2. Swing linear actuator around in a level position to meet the fully closed gate. The contact point is where the gate bracket should be installed on the gate.
3. Weld or bolt the gate bracket to the gate.

## 10 Install Patriot Control Box

The control box should be securely mounted to an object or surface strong enough to support the weight of the box, battery and other components to be installed. The box can be welded or screwed to a suitable mount. The most common mounts are to an adjoining fence panel or wall. Holes can be drilled into the control box for mounting prior to component installation.

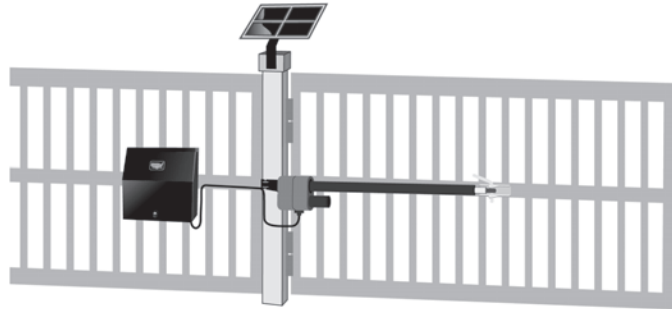

When deciding where to mount the control box remember the actuator cable is 8 feet in length. If possible, mount the control box in a location that will allow the cable to be neatly routed. If it must be longer than the 8 feet, see Step 13b pg 22 Splicing Actuator Cable. Also avoid choosing a mounting location that is near sprinklers.



We have provided knockouts for conduit fittings in the control box bottom right corner. We highly recommend using conduit for all accessory wiring entering the control box. Determine which knockouts are to be used and punch out at this time.

NOTE: One 1 1/4" knockout is already removed for a single gate installation or for the closest gate on a dual gate installation.

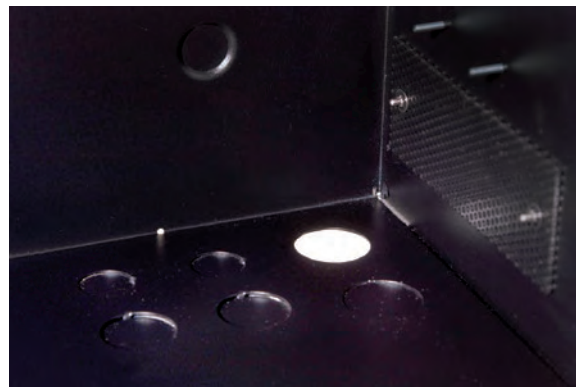

## 11 Install Patriot Control Board

Remove Patriot Control Board from cardboard package and mount on nylon standoffs. Push lightly at each corner to lock board in place.



## 12 Installing Receiver, Smart Charger / Charge Controller, and Entrapment Siren

Before installing the charge controller into the control box connect the wiring harness to the charge controller as shown.

Using the 2 nylon nuts provided install Charge Controller into control box in the upper left corner as shown. Use a 1/4" nutdriver to secure.

Install the receiver into the control box below the Charge Controller using the 2 nylon nuts provided as shown. Use a 1/4" nutdriver to secure.

Plug the green terminal plug into the control board at J2 connector.

Install Entrapment Siren into the control box using the 2 nylon nuts provided as shown. Use a 1/4" nut driver to secure. Connect the Siren power leads to the J4 Terminal as shown.

Black - COMMON GND  
Red - OUTPUT 12V

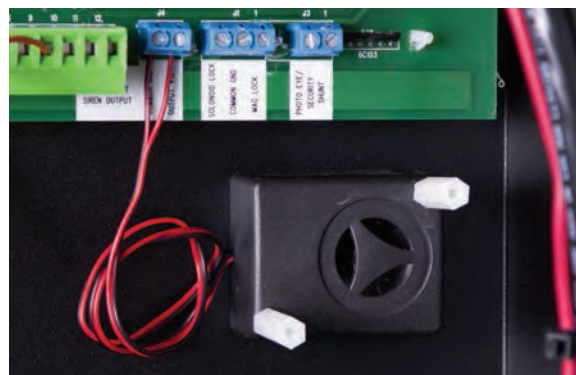

## 13 Install Linear Actuator Cable

The linear actuator is supplied with 8' of cable. Care should be taken to protect the cable from damage that might be caused by animals, lawn equipment etc.

Route the cable into the control box bottom, snap in 1 ¼" plastic grommet, and secure cable to control box using the supplied cable clamp and nylon nut provided as shown. Use a ¼" nutdriver to secure.



**DO NOT plug into control board at this time.**

## 13b Splicing Linear Actuator Cable or Installing 2nd Linear Actuator Cable for Dual Gate System.

When adding an extension cable to a single gate actuator cable or when installing a second gate actuator for Gate 2, the 8 foot actuator cable must be cut and spliced in the following manner.

**Once actuator has been installed:**

1. Locate the linear actuator 8 pin connector. Measure 18 inches from the connector end and cut the black cable. See Figure
2. Save this 8 pin connector and pigtail cable for step 8.
3. Install a rain tight junction box on the Gate 2 hinge post below or near the actuator.
4. Install the extension cable from the junction box at Gate 2 to the Patriot control box. Route the cable through the bottom of the junction box and the Patriot control box. Cut the cable longer than needed for future needs and ease of servicing.



**NOTE: The Patriot II Dual Gate Opener system includes 40 feet of extension cable. If the distance between the junction box and the control box exceeds this distance it is recommended to purchase a cable that will not require additional splices in the cable. USAutomatic Part# 630010 can be custom ordered and purchased in any length. Never make underground splices as moisture in connections will definitely cause system malfunctions.**

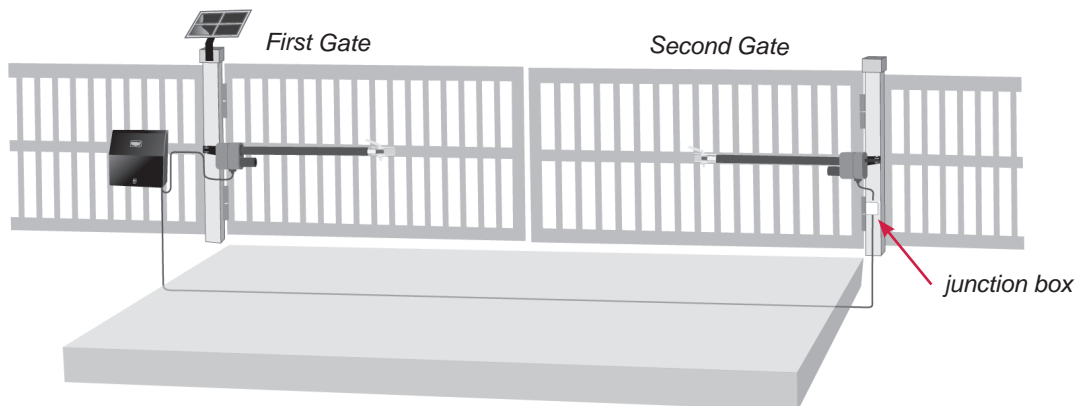



5. Route the linear actuator cable into the junction box through the bottom of the box and determine length. Allow ample slack in the cable for actuator movement when opening and closing the gate. Cut cable longer than needed for future servicing.
6. Remove at least 2 inches of the exterior black jacket on both cables routed into the junction box. Strip back approximately 1/2 inch of insulation from all wires. Connect the wires from each cable, matching color to like color with wire nuts. Pull firmly on all wires to be sure all connections are tight.
7. Install rain tight cover on junction box.
8. Remove at least 2 inches of the exterior black jacket on the pigtail cable (saved from step 2) and on the remaining end of the extension cable previously routed into the Patriot control box (step 4). Strip back approximately 1/2 inch of insulation from all wires. Connect the wires from each cable, matching color to like color with wire nuts. Pull firmly on all wires to be sure all connections are tight.
9. Do not plug into control board at this time.



**IMPORTANT: The length of the extension cable should be as short as possible.**

## 14 Install Battery

The recommended battery for most installations is a 12 volt Group U1 maintenance free battery, 30 to 35 amp hours. This type battery is commonly known as a lawn tractor or wheel chair battery. If the installation is located in an area that has frequent power outages (AC charged systems) or might experience weeks of no sun shine (solar charged systems in region 3) then a larger amp hour battery needs to be considered. A 70 amp hour battery minimum would be recommended for those locations.

The charge controller harness is supplied with two ¼" ring terminals for connection to the battery.

Connect the red wire to the positive post of the battery and the black wire to the negative post of the battery as shown.



Connect the actuator 2 wire connector (or connectors if dual gate) to battery harness.

**NOTE: DO NOT PLUG ACTUATOR(S) INTO CONTROL BOARD AT THIS TIME.**

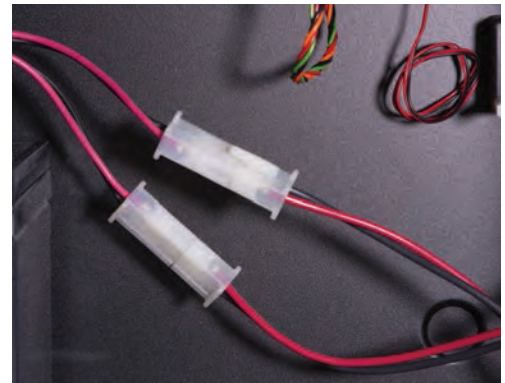

## 15 Install Smart Charger / Charge Controller Power Source (AC or Solar)

The Patriot gate operator's battery is charged by the USAutomatic smart charger / charge controller. The USAutomatic smart charger / charge controller can be powered by an AC transformer supplied with Patriot AC Models **OR** a solar panel supplied with Patriot Solar models. The AC Transformer and the Solar Panel are equipped with a DC plug for easy connection to the smart charger / charge controller.

### 15a Patriot AC Charged System

The AC model Patriot gate operator comes with a low voltage transformer which plugs into the charge controller and can easily provide 575 cycles of operation a day without decreasing the battery charge. In the event AC power goes out the operator will operate for weeks on the battery (if cycles per day are below 20) before needing service. Again, accessories connected to the operator are critical. Always use Solar Friendly accessories to help avoid premature battery failure in cases of power outages.



The unique design of the charging system allows the transformer to be installed away from the gate area if needed. This means that on AC charged systems, the transformer's low voltage wire can be extended avoiding the expense of having an electrician install 120 VAC at the gate area.

Refer to the AC power source cable extension chart below for the exact wire size to be used.

NOTE: AC Transformers are not designed to get wet. Likewise, all splices should be made in a dry enclosure or outdoor box. For convenience use the USAutomatic Charge Cable Extension Pigtailed PN #630038.

Transformer Extension Wire Size				
0 to 100 feet	101 to 250 feet	251 to 500 feet	501 to 750 feet	750 to 1000 feet
18 gauge wire	16 gauge wire	14 gauge wire	12 gauge wire	10 gauge wire

**NOTE: USAUTOMATIC RECOMMENDS A SURGE PROTECTOR ON ALL AC CHARGED INSTALLATIONS.**

## 15b Patriot Solar Charged System

Utilizing the USAutomatic Solar Panel kit, you may use a solar panel to charge the battery. Typically only one panel will be required. The Patriot gate operator is capable of a high number of cycles per day. For information on what you can expect from a solar charged system see page 64. Accessories that are added to your gate operator must be solar friendly accessories and they will be identified as such. For a complete list of accessories, please visit [www.usautomatic.com](http://www.usautomatic.com)



The Solar model Patriot gate operator comes with a 6 watt solar panel and is designed to provide enough cycles a day for most installations without needing more than one solar panel. Care must be taken to ensure the solar panel has full sun throughout the day; partial sun will give partial results. If no sun is present then a solar system is not practical no matter how many panels might be installed. The solar panel must be kept clean and in full sunlight.

The location of the solar panel is critical for proper battery charging. The panel needs to face a South to Southwest direction and be installed at the angle of the supplied solar panel bracket. For proper operation the panel must have unobstructed sun. The Solar Panel needs to be mounted so that it receives full sunlight. Even a small amount of shade or blockage will cause the Solar Panel to cease charging. Something as tiny as a fingertip shadow will affect the Solar Panel.

The solar panel may be moved up to 500 feet from the control box to achieve adequate sunlight. See power source cable extension chart below for proper wire size. For convenience use the USAutomatic 75' Cable Kit Part #520016 or USAutomatic Charge Cable Extension Pigtailed part #630038.

### Optimizing Solar Panel Location

The charge controller automatically determines the charge method installed (AC or Solar) and charges the battery at the optimum charge rate. The solar panel outputs voltage and current to charge the battery. This output voltage will vary slightly as the sun passes over throughout the day. The charge controller can be used to optimize this output voltage.

- To use this feature, identify the time of day for the maximum solar radiation (typically around 2 pm).
- Face the panel toward the sun and observe the "External Power" light on the charge controller, adjust the panel until light comes on and secure in that position.

NOTE: Depending on the time of year and your exact location the output voltage required to illuminate "External Power" light may not be possible. This does not indicate a problem. In this case set panel to face a Southwest position and verify "Solar Power" light is on. Battery is being charged.

Solar Extension Wire Size		
0 to 100 feet	101 to 250 feet	251 to 500 feet
18 gauge wire	16 gauge wire	14 gauge wire



Charge Device  
plugs in here

## 16 Connect Power Source to Smart Charger/ Charge Controller (Transformer or Solar Panel Kit)

The charger / charge controller accepts inputs from either the AC transformer or the solar panel. The transformer and solar panel come with a DC plug for easy installation. Once the charge device is selected and installed connect the DC plug into the charge controller "Power In" located in the upper right corner of the charge controller (see figure).



## 17 Charge Controller Operation Check

Once the charge device is plugged into the charge controller verify the following:

### Transformer:

1. Charge light flashes for 3 seconds and goes off
2. External power and detection lights come on
3. Detection light stays on for 3 seconds, then charging light comes on

### Solar Panel:

1. Charge light flashes for 3 seconds and goes off
2. Solar power and detection lights come on
3. Detection light stays on for 3 seconds, then charging light comes on

**NOTE: Most batteries will not be completely charged when first connected and the charging light should come on when charge controller is first connected. The fully charged light will come on once battery is fully charged.**

When using a solar panel, the charge controller is designed to only charge the battery when there is enough sun to do so. If there is no sun, then the lights on the charge controller should be "OFF". This feature reduces the drain on the battery in solar installations. If transformer is installed, lights are operational at all times.

# 18 Patriot Control Board Information

The Patriot control board is capable of operating two gates. If your installation is a single gate you can operate the gate on the Gate 1 or Gate 2 connector. Set control switch "ON" for the connector being used.

Patriot Control Board

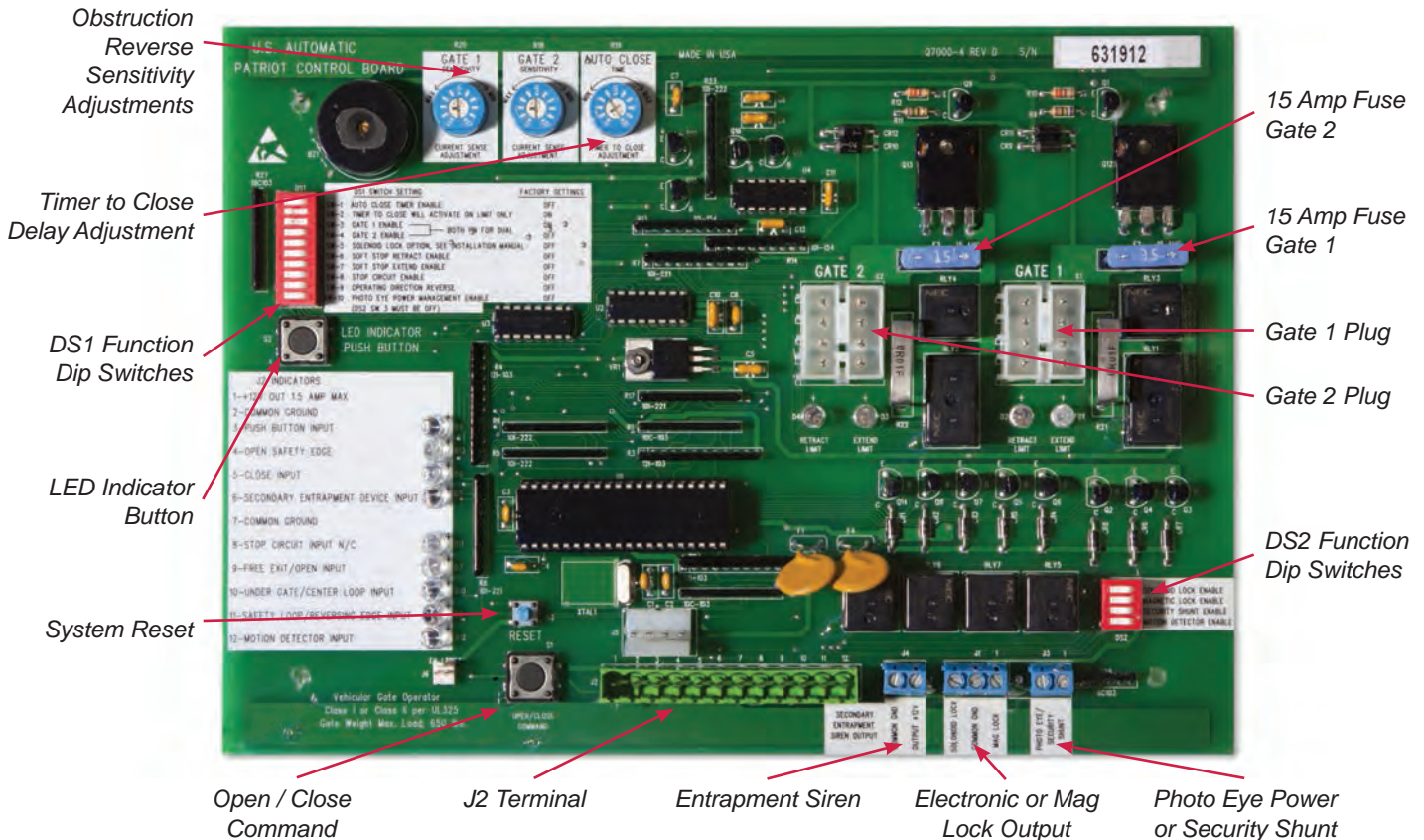

## J2 Terminal Description

The accessory connector is a plug which can be removed from the control board for ease of wiring and troubleshooting purposes.

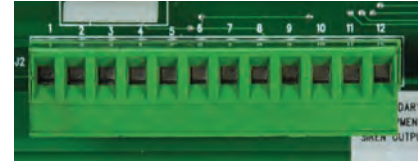

J2 Terminal

Place finger below connector and pull out to remove.

Terminal	
1	+12 vdc Output (Maximum current output 1.5 amp - 1500 milliamps)
2	Common Ground Input -12 vdc
3	Push Button Input (normally open contacts) (Push button, radio control, keypad, etc.)
4	Open Safety Edge (normally open contacts) (Stops gate when opening)
5	Close Input (normally open contacts)
6	Secondary Entrapment Input (normally open contacts)
7	Common Ground Input -12 vdc
8	Stop Circuit Input (normally closed contacts) *DS1 switch #8 must be on for stop circuit function to be enabled.
9	Free Exit / Open Input (normally open contacts) Loop input or any hold open input such as a 7-day timer, telephone access unit, or maintain contact switch (normally open contacts). These devices open the gate and will prevent the gate from closing if the contact is maintained. Once the contacts have been released, the gate can be closed with a closed signal device or the automatic close timer feature. Receiver relay2 pre-wired for latching open.
10	Center Loop or Under Gate Loop Input (normally open contacts)
11	Safety Loop / Photo-eye / Reversing Edge Input (normally open contacts)
12	Motion Detector Input (normally open contacts) Stops a closed gate from opening. Active on closed limit only. *DS2 switch must be on for Motion Detector function to be enabled.

## DS1 Function Dip Switches

ON - Down on right

OFF - Down on left

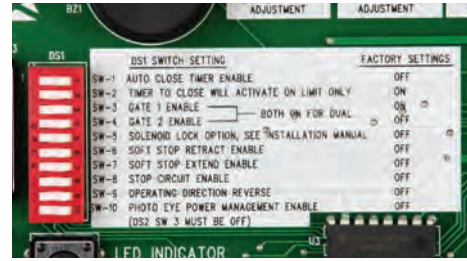

Switch		Setting	Factory Settings are shown in bold type
1	Automatic Close Timer Enable <i>(Not recommended unless safety devices are installed)</i>	ON	Timer to close is activated
		OFF	<b>Timer to close is disabled</b>
2	Timer to Close Function	ON	<b>Timer to close activates only if open limit is activated</b>
		OFF	Timer to close works from any point the gate is stopped
3	Gate 1 Enable	ON	<b>Gate 1 operator enabled to function</b>
		OFF	Gate 1 operator disabled
4	Gate 2 Enable <i>(both gates on for dual)</i>	ON	Gate 2 operator enabled to function
		OFF	<b>Gate 2 operator disabled</b>
5	Solenoid Lock Option <i>(see accessory wiring page 43)</i>	ON	DS2 SW 1 must be on, output +12vdc with delay when gate is operating
		OFF	<b>No function. See DS 2 SW 1 Pg 30</b>
6	Soft Stop Retract Enable	ON	Enables soft stop for retract position
		OFF	<b>Disables soft stop for retract position</b>
7	Soft Stop Extend Enable	ON	Enables soft stop for extend position
		OFF	<b>Disables soft stop for extend position</b>
8	Stop Circuit Enable <i>(A normally closed pushbutton is required)</i>	ON	Allows for a stop button input to be utilized
		OFF	<b>Disables the stop button function</b>
9	Operating Direction Reverse <i>(Must be on for push to open installations to operate correctly)</i>	ON	Push to Open
		OFF	<b>Pull to Open</b>
10	Photo Eye Power Management Enable	ON	Enables PEPM - <i>see page 44-45</i>
		OFF	<b>Disables PEPM</b>

## DS2 Function Dip Switches

ON - Down on right

OFF - Down on left

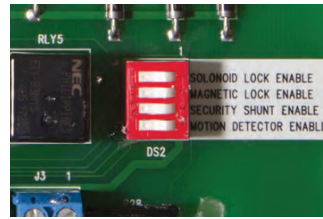

DS2 Switches

Switch		Setting	Factory Settings are shown in bold type
1	Solenoid Lock Enable / Gate in Operation Indicator	ON	Solenoid lock output energizes half second before gate begins to move and releases 3 seconds after the gate begins to move. For gate in operation indicator to operate DS1 SW 5 must also be ON. (Energizes = +12 vdc output 1.5 amp max)
		OFF	<b>Solenoid lock / gate in operation indicator is inactive</b>
2	Magnetic Lock Enable	ON	Magnetic lock output energizes on Master Limit and releases half second before gate begins to open. (Energizes = +12 vdc output 1.5 amp max)
		OFF	<b>Magnetic lock output is inactive</b>
3	Security Shunt Circuit Enable / Open Gate Indicator	ON	Security shunt circuit relay is active (closed circuit)(wire in parallel) Relay activates half second before gate begins to open and stays activated until 4 seconds after gate reaches a closed limit
		OFF	<b>Security shunt circuit relay is inactive (open circuit)</b>
4	Motion Detector Enable	ON	Enables motion detector input J2 pin 12 (if input is activated, gate will not open)
		OFF	<b>Disables motion detector input J2 pin 12</b>



## Current Sense Adjustments and Entrapment Alarm

The current sense adjustment feature designed into the control board allows you to adjust the amount of pressure the gate will apply to an object before the gate is stopped and reversed by the control board.

The Patriot control board has 2 current sense adjustment dials located in the upper left corner of the control board. These adjustments control the amount of current the control board will allow the motor to draw from the battery to operate your gate. Maximum sensitivity is the least amount of current (or force) allowed.

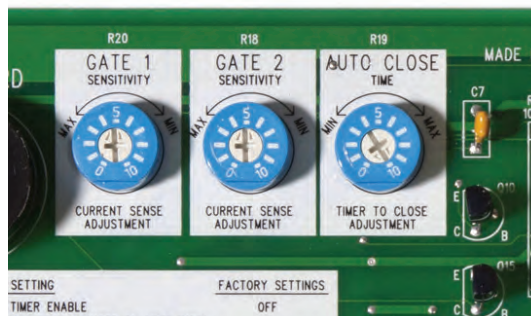

We intentionally set the sensors at a medium sensitivity setting. This may need to be adjusted to achieve gate movement of larger gates without tripping the sensitivity circuit and causing the gate to reverse direction. If the gate reverses direction twice and then stops, the control board will need to be reset.

A typical adjustment setting is between 4 to 7 on the adjustment dial. A setting of 8 or more may be required on very large gates. If a setting above 8 is required for proper operation without just cause, you should check the gate, gate hinges or linear actuator for possible problems.

### Testing the Sensitivity feature:

Sensitivity feature is inactive for the first second of gate operation.

While the gate is operating (open or closed direction) apply force to the gate until it stops and reverses. If traveling in the open direction the gate should reverse about 1 foot, if traveling in the closed direction the gate will reverse to the fully open position.

### Entrapment alarm:

The entrapment alarm is installed to give an audible alert whenever the gate sensitivity feature is activated twice during an open or close cycle.

For example, the gate is closing and is stopped by some object, it will then reverse direction. If the gate encounters a second object before reaching the fully open position it will stop again and enter a hard shutdown, which will set off the entrapment alarm. The alarm will sound for 5 minutes or until the reset button on the control board is pressed and released. The hard shutdown will require the reset button to be pressed to place the gate operator back into operation.



## 19 Control Board Dipswitch Setting Verification

NOTE: This check must be performed before operating the gate for the first time. Failure to do so may damage the gate operator.

Before operating the gate lets make sure the Patriot control board dipswitches are set correctly for your installation. Locate the dipswitches on the Patriot control board.

Factory default dipswitch settings are 2 and 3 on.

ON - Down on right

OFF - Down on left

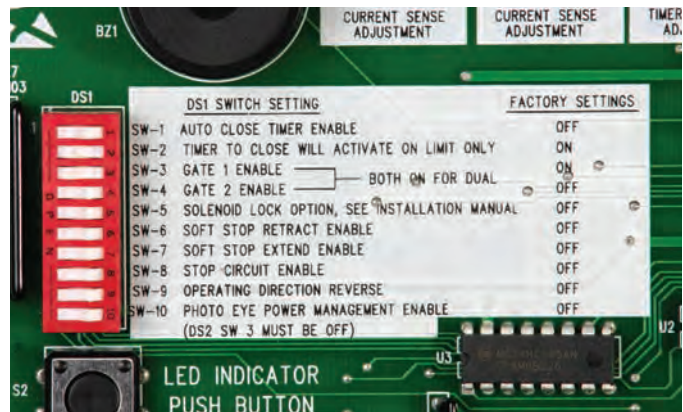

**Identify your installation below and verify the standard dipswitch settings:**

<b>PATRIOT I</b>	(PULL TO OPEN)	Dipswitches 2, 3 should be in the on position
<b>PATRIOT I</b>	(PUSH TO OPEN)	Dipswitches 2, 3, 9 should be in the on position
<b>PATRIOT II</b>	(PULL TO OPEN)	Dipswitches 2, 3, 4 should be in the on position
<b>PATRIOT II</b>	(PUSH TO OPEN)	Dipswitches 2, 3, 4, 9 should be in the on position

**NOTE: PUSH TO OPEN INSTALLATIONS ONLY:**

Push to Open installations do not require rewiring of the actuator harnesses. The Patriot control board dipswitch 9 eliminates the need to do this. Failure to turn dipswitch 9 ON will cause improper gate operation. Verify your installation type and verify dipswitch settings.

## 20 Gate Delay Feature - For Bi-parting Dual Gate Systems with overlapping gates and/or electric gate locks.

It is necessary to activate the gate delay feature anytime dual gates overlap in the closed position or have an electric gate lock. To activate this feature simply turn DS2 switch 1 on. The actuator plugged into Gate 2 will always open 2 seconds after Gate 1 opens and will always close 2 seconds before Gate 1 closes.

## 21 Optional Soft Stop for Retract or Extend Position

The Patriot control board is equipped with a selectable soft stop feature for retract, extend or both directions, if desired. Understanding how this feature operates is required before turning on any control switches or possible control board damage may occur.

The soft stop feature reduces the motor voltage for approximately the last 18" of travel. This feature is primarily used on long light weight gates that tend to flex back and forth (gate slap) when gate stops. Another common way to reduce the gate slap is to install a stop plate or post for the gate to contact at travel end.

## Instructions for Soft Stop Set Up on New Installations

### **Soft stop setup for retract and extend on new installation only.**

1. Disconnect the linear actuator from the gate.
2. Rotate the extension screw counter-clockwise (turn to left) 6 complete rotations.
3. Reconnect the linear actuator to the gate.
4. The gate should now be about 18" from the fully open position.
5. Turn on the DS1 switch 6 and 7 ON at this time.

### **Soft stop setup for extend on new installation only.**

1. Turn on the DS1 switch 7 ON at this time.

### **Soft stop setup for retract on new installation only.**

1. Disconnect the linear actuator from the gate.
2. Rotate the extension screw counter-clockwise (turn to left) 6 complete rotations.
3. Reconnect the linear actuator to the gate.
4. The gate should now be about 18" from the fully open position.
5. Turn on the DS1 switch 6 ON at this time.

## Instructions for Soft Stop Set Up on Existing Installations

### **Soft stop setup for retract and extend on existing installation only.**

1. Adjust retract and extend limit switches so that the gate is stopping about 24" short of the desired retracted and extended stop position.
2. Turn on the DS1 switch 6 and 7 ON at this time.
3. Operate the gate and verify soft stop feature was activated.
4. Adjust retract and extend limit switches to the desired final stop position.

### **Soft stop setup for extend on existing installation only.**

1. Adjust extend limit switch so that the gate is stopping about 24" short of the desired extended stop position.
2. Turn on the DS1 switch 7 ON at this time.
3. Operate the gate and verify soft stop feature was activated.
4. Adjust extend limit switch to the desired final stop position.

### **Soft stop setup for retract on existing installation only.**

1. Adjust retract limit switch so that the gate is stopping about 24" short of the desired retracted stop position.
2. Turn on the DS1 switch 6 ON at this time.
3. Operate the gate and verify soft stop feature was activated.
4. Adjust retract limit switch to the desired final stop position.



## 22 Connect Linear Actuator Cable to Control Board

The 8 pin plug on the linear actuator cable must connect to either the Gate 1 or Gate 2 connector on the control board. Once cable is connected verify that the corresponding control switch for Gate 1 or Gate 2 is turned ON. Gate 1 port is recommended for single gates or the closest gate in a dual gate system.

Before connecting the actuator cable to the control board check the following:

- Verify that all previous steps were performed.
- Verify that the battery connections are correct red lead to positive and black lead to negative.
- Verify that nothing is in the path of the gate. If by chance it begins to move when power is applied, be prepared to disconnect the actuator cable.

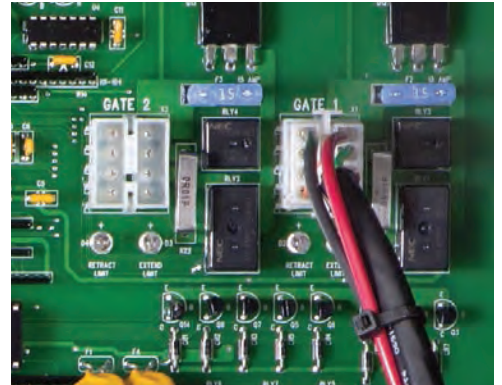

### Patriot I (Single Gate)

- Locate the actuator cable and plug it into the Gate 1 actuator connector (see image) on the control board. You might hear a beep from the control board when power is supplied. This is not a problem.

### Patriot II (Dual Gates)

- Locate the closest gate's actuator cable and plug it into the Gate 1 actuator connector (see image) on the control board. You might hear a beep from the control board when power is supplied. This is not a problem.
- Locate the farthest gate's actuator cable and plug it into the Gate 2 actuator connector.

Patriot II (Dual Gates) with overlapping gates or electrical lock requiring gate delay. See section 20 on page 32.

## 23 Operating Gate for the First time

**Before operating the gate for the first time please verify the following items:**

1. Linear actuator is in the retracted position. If dual gate check both.
2. Press LED indicator and verify that the retract limit light is ON. If dual gate check both.
3. Verify that DS1 switches on control board are set correctly for your installation per the following chart:

## NO SOFT STOP

DS1 Switch Settings Gate 1 only (No soft stop)
Switch 3 (Gate 1 enable) ON
DS1 Switch Settings Gate 2 only (No soft stop)
Switch 4 (Gate 2 enable) ON
DS1 Switch Settings Gate 1 & Gate 2 only (No soft stop)
Switch 3 & 4 ON

## SOFT STOP FOR RETRACT AND EXTEND ARE ON

DS1 Switch Settings Gate 1 only (Soft stop for retract and extend are ON)
Switch 3 (Gate 1 enable) ON
Switch 6 (Soft stop retract enable) ON
Switch 7 (Soft stop retract enable) ON
DS1 Switch Settings Gate 2 only (Soft stop for retract and extend are ON)
Switch 4 (Gate 2 enable) ON
Switch 6 (Soft stop retract enable) ON
Switch 7 (Soft stop retract enable) ON
DS1 Switch Settings Gate 1 & Gate 2 only (Soft stop for retract and extend are ON)
Switch 3 & 4 ON
Switch 6 (Soft stop retract enable) ON
Switch 7 (Soft stop retract enable) ON

Locate the Open / Close command button on the Patriot control board. This button will start the gate when pressed once; pressing it again will stop the gate.

Press and release the Open / Close button. The linear actuator should begin to extend. Allow the gate to travel to the factory adjusted extend position. The gate should typically stop short of the desired extended position.

Press and release the Open / Close button again. The linear actuator should begin to retract. Allow the gate to travel to the factory adjusted retract position. The gate should typically be very close to the desired retracted position.



## 24 Making Final Adjustments (Retract and Extend Limits and Sensitivity)

The independent retract and extend limit adjustments are located on the bottom side of the linear actuator. These will need to be adjusted. Remove the dust plug to make adjustments. A flat blade screwdriver is included with the operator for adjustment purposes.

**Caution: Do not use a battery powered screw driver to make these adjustments or damage to the limit assembly may occur.**

To increase the extend distance of the extension tube turn the extend screw clockwise.

To decrease the extend distance of the extension tube turn the extend screw counterclockwise.

To increase the retract distance of the extension tube turn the retract screw clockwise.

To decrease the retract distance of the extension tube turn the retract screw counterclockwise.

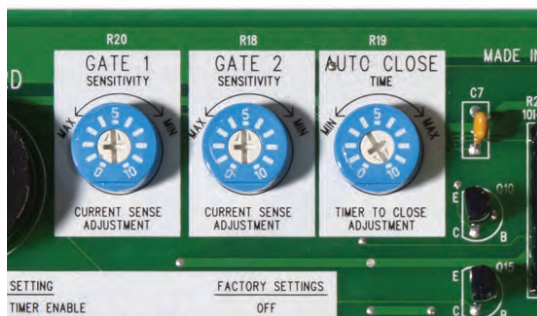
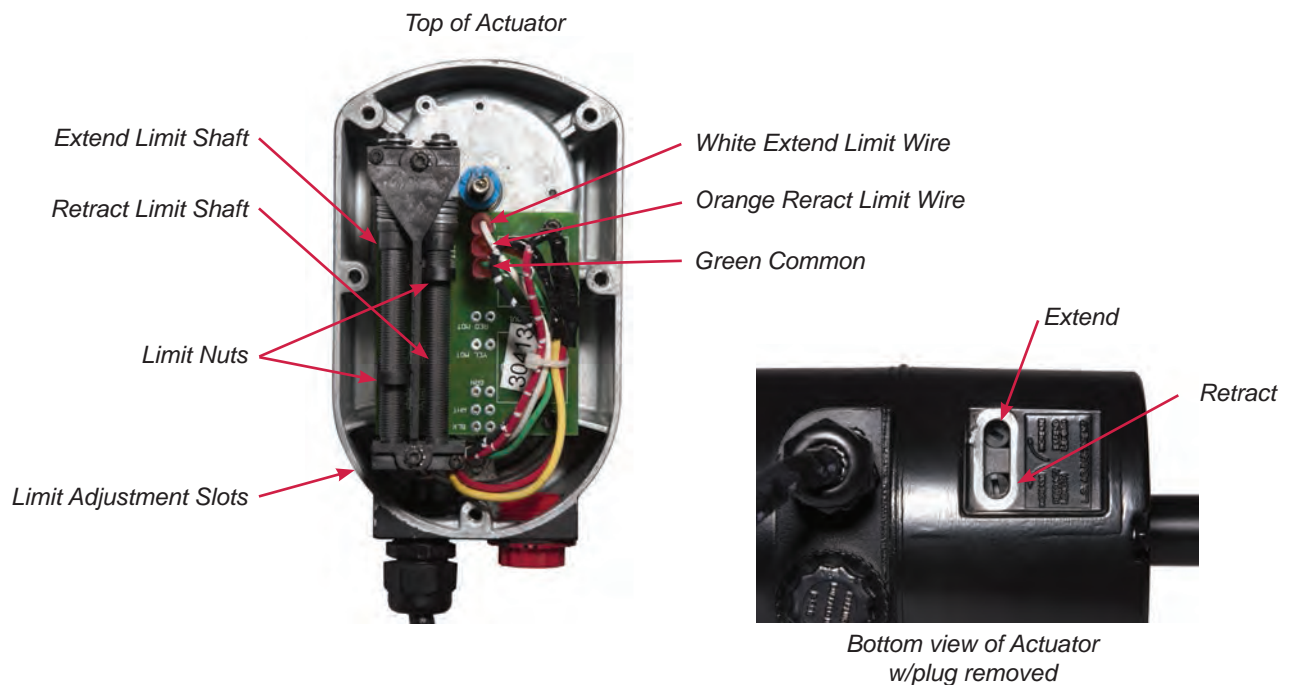

The sensitivity adjustments are located on the control board and explained on page 31. Both sensitivity settings should be individually adjusted on dual gate systems. On single gate systems, adjust the setting for the actuator plug being utilized (Gate 1 or Gate 2) and then match the setting on the other sensitivity adjustment. Refer to the Current Sense Adjustments and Entrapment Alarm section.

## 25 Programming Transmitter and Receiver

Operating frequency 433.92 MHz.

Receiver can store up to 42 unique transmitter dipswitch code settings.

### Transmitter Setup:

*(It is recommended that the dipswitch code be changed from the default factory setting)*

1. Open the battery compartment door and locate the dipswitches.
2. Change the dipswitches to the settings you prefer, record for future reference in the table below.



Switch Position	Switch 1	Switch 2	Switch 3	Switch 4	Switch 5	Switch 6	Switch 7	Switch 8	Switch 9
+									
0									
-									

### Transmitter Left Button to Receiver Programming: *(standard Open/Stop/Close function)*

1. Press and hold the left transmitter button down. Red light on transmitter should be on.
2. On the receiver, push the P1 push-button until the green LD light comes on.
3. Release both buttons. Transmitter left button to receiver programming is complete.

### Transmitter Right Button to Receiver Programming:

*(Hold-Gate-Open) (Only if auto close timer is enabled)*

1. The 2-channel receiver allows for programming the P2 relay from momentary mode (default) to latching mode. Transmitter right button can be programmed to hold gate open, over-riding the auto-close feature if activated.
2. Press and hold the right transmitter button down. Red light on transmitter should be on.
3. Press the P2 push-button until the green LD light comes on.
4. Release both buttons. Transmitter right button to receiver programming is complete.

### Receiver Programming: Relay P2 programming from momentary to latching mode (to hold gate open)

1. Press the P2 push-button until the green LD light comes on, then release. Green LD light should be steady.
2. While the green LD light is on, push the P1 push-button down and release. Green LD light should be flashing. Latching mode is set.

### Verifying Receiver P2 relay is programmed to latching mode:

1. Press the P2 push-button until the green LD light comes on, then release.
2. Green LD light should be flashing. If green LD light is steady, redo the Receiver Programming section above.



### Resetting receiver P2 relay to momentary mode:

1. Press the P2 push-button until the green LD light comes on, then release. Green LD light should be flashing.
2. While the LD light is flashing, push the P1 push-button down and release. Green LD light should be steady. Momentary mode is set.



### Erasing Single Transmitter from Receiver Memory:

The dipswitch settings of the transmitter to be deleted must be known. If known follow the steps below.

1. Set the dipswitches in a transmitter to match the switch settings of the transmitter code to delete.
2. Press and hold the left transmitter button.
3. On the receiver, push the P1 push-button until the green LD light comes on. Then release both.
4. Press and hold the right transmitter button.
5. On the receiver, push the P2 push-button until the green LD light comes on. Then release both.
6. Transmitter is now erased from receiver memory.

### Erasing all Transmitters from Receiver Memory:

1. Press the P2 button on the receiver until the green LD light comes on. Then release P2 button.
2. While LD light is on press the P1 and P2 buttons simultaneously and hold until the green LD light begins to blink slowly. It should blink 4 times then all transmitter codes are erased.

## 26 Install Safety Signs

Install the 2 warning placards in the gate area where they are visible from the inside and outside of the gate. These are required per UL 325 to make persons aware of the possible danger of an automated gate.



## 27 Emergency Manual Release

**NOTE: Before detaching actuator arm from gate, turn DS1 dipswitch 3 and 4 to the OFF position (page 29). This will keep the actuator from operating while arm is disconnected from the gate.**

Remove the manual release pin at the gate bracket and open the gate by hand. Secure the gate before attempting to pass through.

Manual Release Pin

Secure in place with pull clip or with #2 lock. Release pin is predrilled for this purpose.





# ENTRAPMENT ZONES

## Areas of concern in a typical swing gate system are:

- Zone 1** The leading edge of the gate & catch post.
- Zone 2** Area between the gate and hinge post.
- Zone 3** The arc of the gate or gate path.
- Zone 4** The space between the gate when open and any obstruction such as fence, wall, landscaping, etc.
- Zone 5** The point where two bi-parting gates come together when closing. (Not shown below)

Every installation is unique and it is the installer's responsibility to recognize and remedy all safety concerns. Please consult a qualified dealer or the factory for a complete explanation of the remedies available and additional tips pertaining to your installation.

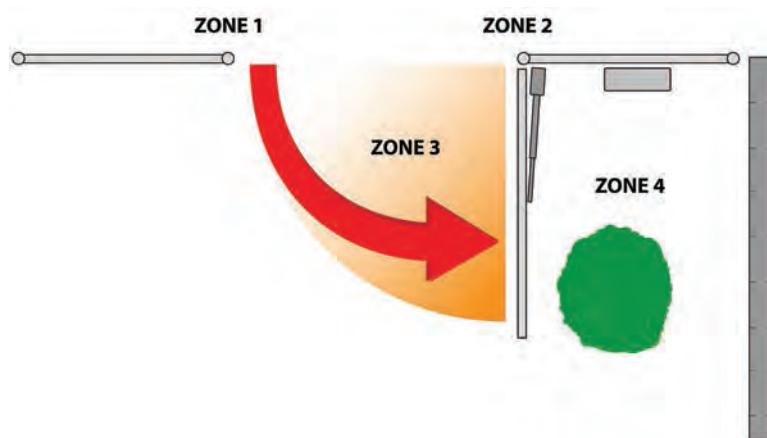

# PERIODIC SERVICE

All gate operators require periodic checking and adjustments of the control mechanism for force (load), speed and sensitivity. All accessories and secondary safety devices must be checked. Secondary safety devices need to be checked at least once a month for proper operation.

Periodic checking is also advised for the following:

1. Battery terminals for corrosion, clean with baking soda solution.
2. Hinges and pivot points need to be greased.
3. Mounting bolts for correct tightness.
4. Inspect weld points for cracks or other defects.
5. Inspect wiring for cuts, nicks or other defects.
6. Inspect hinge post to ensure it is not moving or twisting.
7. Verify proper operation of charging system, refer to charge controller operation check.
8. Verify monthly that the inside of the control cabinet remains clean and free of insects. Do not spray control board with bug spray or oil based products.
9. Opening or closing time should be approximately 12 seconds. If the time begins to increase and the gate begins to slow down, the battery needs to be tested.



# Accessories

## Wireless Keypad

Part Number 050500

PUK code \_\_\_\_\_

## Metal Wireless Keypad

Part Number 050550

PUK code \_\_\_\_\_

This tamper-resistant, weatherproof, programmable Wireless Keypad can be mounted outside your gate and offer convenient access without having to carry a transmitter.

### Terms to understand:

**Access Code** – The 2 to 5-digit code used to open the gate (24 unique codes are possible). If access code is less than 5 digits it requires the # sign after code is entered. Example: “2 #.” If code is 5 digits the # sign is not required.

**On the metal keypad, A and B replace \* and #.**

**Master Password** – The 5-digit code used to access programming features. Factory default is “11111”. This should be changed for security reasons.  
**NOT USED TO OPEN GATE.**

**Relay 1** – The receiver has 2 relays. P1 (relay 1) is pre-wired to the J1 connector to open and close the gate.

**Relay 2** – The receiver has 2 relays. P2 (relay 2) is pre-wired to the “Open/Free Exit” on J1 connector to OPEN only.

**Keypad Security Code (Dip Switch Code)** – This code makes your keypad unique to your installation. Keypad does not have dip switches like the transmitter; instead it has virtual dip switches which must be programmed.

**PUK Code** – “Password Unblocking Key.” The PUK code is located inside the keypad and is needed when the master password has been lost. Record in space above for future reference. Must be 5 digits long.

**“ \* ” Key** – located on the keypad is used to cancel last command entered.

**Red Light Blinks** – When blinking, the keypad is sending a signal to the receiver. Valid access code was entered.

### Metal Keypad - 5 Key Flashes Blue

**Note: Do not install keypad until “Learning Keypad to Receiver” has been completed.**

### Programming Wireless Keypad

**NOTE: The Master Password is NOT an access code. This is a MASTER programming code used to access the programming of the keypad. It is not used to open the gate.**

**Programming New Master Password:** Once created record here for reference \_\_\_\_\_

1. Enter the Master Password “11111”.
2. Enter “8” If correct, 2 short beeps (if 1 long beep is heard, start over with step 1).
3. Enter the Master Password (up to 5 digits), if less than 5 digits, “#” is required.
4. Enter “8”
5. Enter the Master Password again to verify.
6. Press “8” If correct, 2 short beeps - New Master Password is set (If 1 long beep is heard, start over with step 1).



**Programming Master Password Back to Factory Default: (11111)**

1. Enter "11111".
2. Press "8" (long beep).
3. Enter PUK code. (PUK must be 5 digits).
4. Press "8".
5. Enter PUK code to confirm.
6. Press "8" (2 beeps) Master password reset complete.

**Programming the Keypad for Operation**

**Create Access Code: (Code you use to operate the gate)**

1. Enter the Master Password "11111".
2. Enter "9" If correct, 2 short beeps (if 1 long beep is heard, start over with step 1).
3. Enter the new Access Code (up to 5 digits), if less than 5 digits, "#" is required.
4. Enter "9"
5. Enter the new Access Code again to verify.
6. Enter "1" or "2" representing the relay (relay 1 or 2 in the receiver) you want to control.  
1 = OPEN/CLOSE      2 = OPEN ONLY
7. If correct, 2 short beeps (if 1 long beep is heard, start over with step 1).

**Changing Keypad Security Code:**

This keypad has a virtual dipswitch used to create your Security Code. The virtual dipswitch contains nine 3-position switches. To ensure neighboring keypads do not interfere with each other, the virtual switches should be positioned in a random pattern, using the following procedure.

**Example of random positioning of the virtual dipswitches to create a Security Code is shown below. To enter the Security Code, enter the dipswitch number, followed by the dipswitch position character.**

**The Security Code would be entered as: 1# 20 3\* 4\* 5# 6\* 7# 80 9\***

Dipswitch Position	Switch 1	Switch 2	Switch 3	Switch 4	Switch 5	Switch 6	Switch 7	Switch 8	Switch 9
#	X				X		X		
0		X						X	
*			X	X		X			X

Use table below to create your random security code and follow steps below to program your keypad.

Dipswitch Position	Switch 1	Switch 2	Switch 3	Switch 4	Switch 5	Switch 6	Switch 7	Switch 8	Switch 9
#									
0									
*									

1. Enter the Master Password.
2. Enter "6" If correct, 2 short beeps (if 1 long beep is heard, start over with step 1).
3. Enter the Security Code created in the previous table. If correct, 2 short beeps after each switch number and switch position combination is entered.
4. Enter "#"
5. Enter "6"
6. If correct, 2 short beeps (if 1 long beep is heard, start over with step 1).



## Learning Keypad to Receiver:

### **Create Communication with Receiver Relay 1:** (Security Code/Dip Switches)

For open, close, stop functions.

1. Carry keypad to receiver location for programming.
2. Enter the Access Code for relay 1 on the keypad and continue to press the last key entered (red light blinks).
3. Press P1 (learn button) on the receiver until LD (green light) comes on and relay clicks.

### **Create Communication with Receiver Relay 2:** (Security Code/Dip Switches)

Not required unless using Relay 2.

For open only function or hold gate open function.

1. Carry keypad to receiver location for programming.
2. Enter the Access Code for relay 2 on the keypad and continue to press the last key entered (red light blinks).
3. Press P2 (learn button) on the receiver until LD (green light) comes on and relay clicks.

### **Deleting Single Access Code:**

1. Enter the Master Password.
2. Press the "7" key. If correct, 2 short beeps (if 1 long beep is heard, start over with step 1).
3. Enter the Access Code to be deleted.
4. Press the "7" key.
5. Reenter the Access Code to be deleted.
6. Press the "7" key. If correct, 2 short beeps (if 1 long beep is heard, start over with step 1).

### **Deleting All Access Codes:**

1. Enter the Master Password.
2. Press the "7" key. If correct, 2 short beeps (if 1 long beep is heard, start over with step 1).
3. Reenter the Master Password.
4. Press the "7" key.
5. Reenter the Master Password.
6. Press the "7" key. If correct, 2 short beeps (if 1 long beep is heard, start over with step 1).

## Electric Gate Lock

Part Number 070510

### Suitable for solar and AC charged systems.

The Patriot Control Board will energize and release a 12 vdc electric gate lock or de-energize and release a magnetic gate lock 1 second before the gate or gates begin to open.

### To activate the electric gate lock delay circuit

Turn DS2 switch 1 on. This also activates the Gate Delay Feature on Dual Gate systems.

Connect the negative (12vdc-) wire from the gate lock to J1 Common Gnd terminal

Connect the positive (12vdc+) wire from the gate lock to J1 Solenoid Lock terminal.

For Dual Gates, see Gate Delay Feature Section 20, pg 32.



## Magnetic Gate Lock

*(Non-USAutomatic product)*

### Not suitable for solar charged systems. Suitable for AC charged systems.

To activate the magnetic lock delay circuit, turn DS2 switch 2 on. Connect the negative (12vdc-) wire from the magnetic gate lock to J1 Common Gnd terminal. Connect the positive (12vdc+) wire from the magnetic gate lock to J1 Solenoid Lock terminal.

NOTE: On dual gates with a magnetic gate lock, it is also necessary to turn DS2 switch 1 on to activate the Gate Delay Feature.

For Dual Gates, see Gate Delay Feature Section 20, pg 32.

## Exit Sensor (Solar friendly device)

Preferred Technologies CP-3-3W

Part Number 070305

The driveway exit sensor is a magnetic device that installs below ground beside the drive. A magnetic field is established which when interrupted by a moving metal object will send a signal to open the gate. This sensor is supplied with a 80 foot cable and is typically installed inside the property beside the drive to automatically open the gate when a car passes. This type of sensor is not a safety device.

Sensor can be ordered with cable lengths that fit the installation. (Standard 80')

It is recommended to install this sensor and cable in PVC conduit.

Wire as follows: Red wire – connect to J2 pin 1  
Shield (braided wire) – connect to J2 pin 2  
Black wire – connect to J2 pin 9



## 7 Day Timer (Solar friendly device)

Part Number 550015

The optional 7 day timer can be used to open the gate at a preset time and if the auto close feature of the gate operator is being used the gate can then close automatically at a preset time. The timer is supplied with a 3 wire harness that easily wires to the control board. Connect wires from timer to control board J2 connector as follows:

- Red wire connect to J2 pin 1
- Black wire connect to J2 pin 2
- Blue wire connect to J2 pin 9



## Photo Eye

Part Number 550010

Wiring Photo Eye to Patriot Control board  
(serial numbers above 600001 Call factory for older models)

Photo eyes are recommended for all gate installations to provide safety and protect objects that might be in the gate path. Typically a swing gate needs two sets of photo eyes for the best area protection (see figure).

One set of photo eyes pointing across the drive on the outside of the hinge post (A). The second set mounted across the drive at the point where the gate is fully opened (B). The photo eye must be installed where the gate does not break the beam.

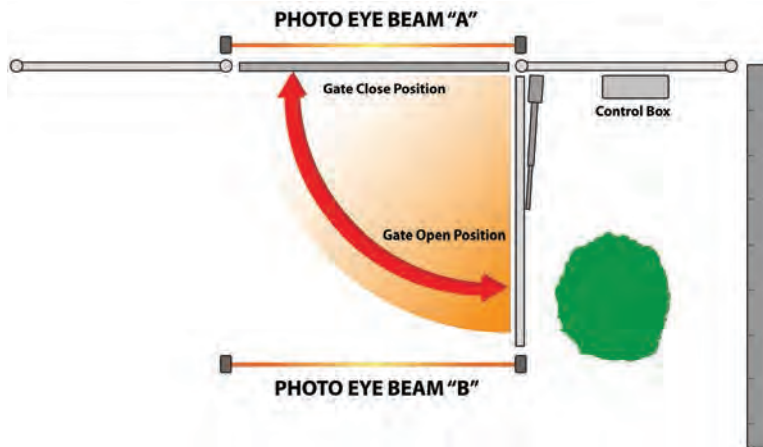

The primary unit (Receiver) should be installed close to the control box.

It requires 4 wires to be installed from the unit to the control box.

The second unit (Transmitter) should be installed on the opposite side of the drive.

It requires 2 wires to be installed from the unit to the control box.

The two units must face each other to establish the beam (maximum distance 40 feet).

The Photo Eye Power Management software installed in the control board makes it possible to power photoeyes without pre-maturely draining the battery.

When utilizing the PEPM software the photo eye will only be powered up when the gate is about to close or traveling in the closed direction. The PEPM software allows the gate to be held open without battery drain and does not require any additional solar panels.

The photo eye must be wired as shown and the correct dipswitches must be turned on for the PEPM software to work correctly. Detailed instructions are below with illustration.

1. Connect jumper wire from J2 pin 1 to the left "Photo Eye / Security Shunt" terminal
2. Connect photo eye power +12 vdc to the right "Photo Eye / Security Shunt" terminal
3. Turn on dipswitch DS2 switch 3 in bottom right corner of control board (temporary while adjusting beam)
4. Place gate in the open or mid travel position (allows power to the photo eye).
5. Wire the RX relay N/O contact from the photo eye to J2 pin 11.
6. Wire the RX relay common from the photo eye to J2 pin 2 or 7.
7. Wire the photo eye ground (power ground) to J2 pin 2 or 7.
8. Install Photo eye and adjust beam – verify proper operation.
9. Once installed turn OFF dipswitch, DS2 switch 3.
10. Turn ON dipswitch, DS1 switch 10 in the upper left corner of control board.
11. Test photo eye for proper operation, when gate is closing and beam is broken gate should stop and reverse.

**NOTE: Power is only applied to photo eye just prior to closing and when gate is going closed.**

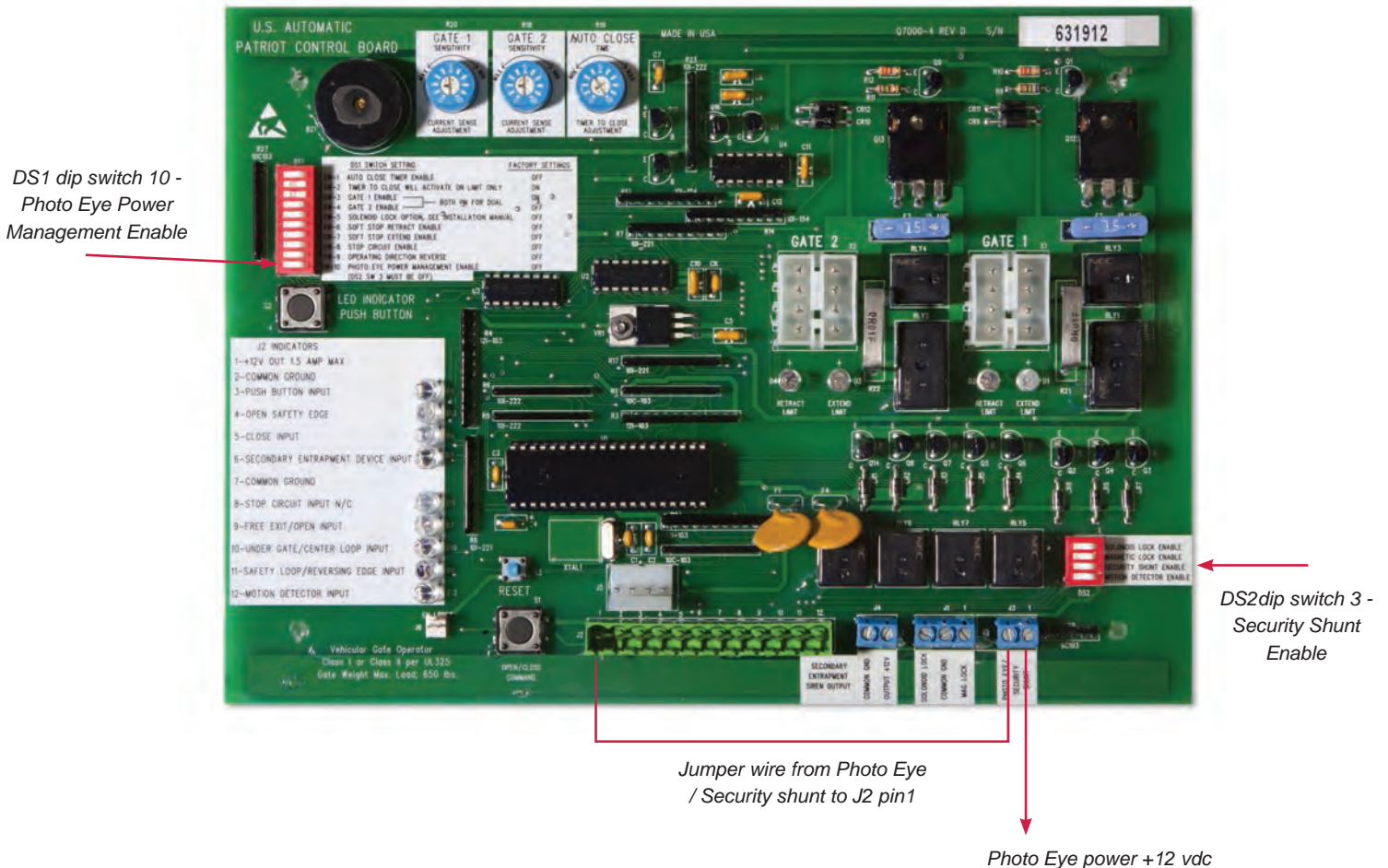

## Garage Door Receiver

Part Number 030214

The receiver provided with the Patriot gate operator operates at 433 MHz and might or might not be compatible with your garage door. If receiver frequency is not compatible the optional "Garage Door Receiver kit" can be easily installed in the garage.

The kit contains receiver, transformer and a wire harness that easily installs to the existing garage door. One receiver will be needed for each garage door. All existing transmitters used for garage door will continue to operate. They are not being disconnected. Mounting hardware included.

To program open receiver box cover. Place small screw driver in slot to open. Press the learn button. Then press the transmitter button that will be used to open the garage. See garage operator for connecting the 2 wires supplied.

If needed, 4 button transmitters are available.



## Push to Operate Wireless Button

Part Number 030215

The Push to Operate transmitter is designed for indoor or outdoor wireless installation. Install to allow operation of the gate or garage by simply pressing the pad. The button is a pressure sensitive pad. Press the pad and an audible tone is generated. Programming is identical to transmitter programming. Installation hardware is included. Compatible with all USAutomatic receivers.



## 2 Button LCR Transmitter

Part Number 030210

Standard Transmitter for all USAutomatic operators

Operating Frequency 433.92 MHz



## 4 Button LCR Transmitter

Part Number 030212

Operating Frequency 433.92 MHz





## **I2/24 Receiver**

Part Number 030207

- Ideal for all brands of gate operators powered by AC. Not recommended for solar applications.
- Dual channel normally open contacts.
- Two relays - Primary relay momentary, secondary relay has momentary or latching mode.



## **External Reset Button**

Part Number 630060

Plugs into Patriot Control Board and provides an external system reset option. (not waterproof)



## **Charge Cable Extension Pigtails**

Part Number 630038

Provides easy splicing of charging device cable. Works with AC Transformer and Solar Panel.



# Troubleshooting Guide

## Introduction

The Patriot control board is equipped with three unique features to assist in troubleshooting a gate system.

1. The first and most helpful is the series of LED indicating lights. These lights will help to identify problems with the actuator limit switches and all control circuits. To use the indicators, press and hold the “LED Indicator” button on the control board. (The LED’s are not active unless the LED indicator push button is pressed and held to save battery life). Any circuits or limit switches that are activated will be obvious by the illumination of the adjacent LED.
2. The second feature to assist in troubleshooting is the current sense beeper. The beeper will sound anytime the current sense circuit is activated. This is useful in detecting a false reverse due to an improper or too sensitive current reverse setting, or a gate, which is requiring excessive force to move
3. The third feature to assist in troubleshooting is the on board “Open / Close Command” pushbutton. This button makes it possible to operate the gate with the twelve terminal wiring plug removed without having to short across terminal pins.

Patriot Control Board

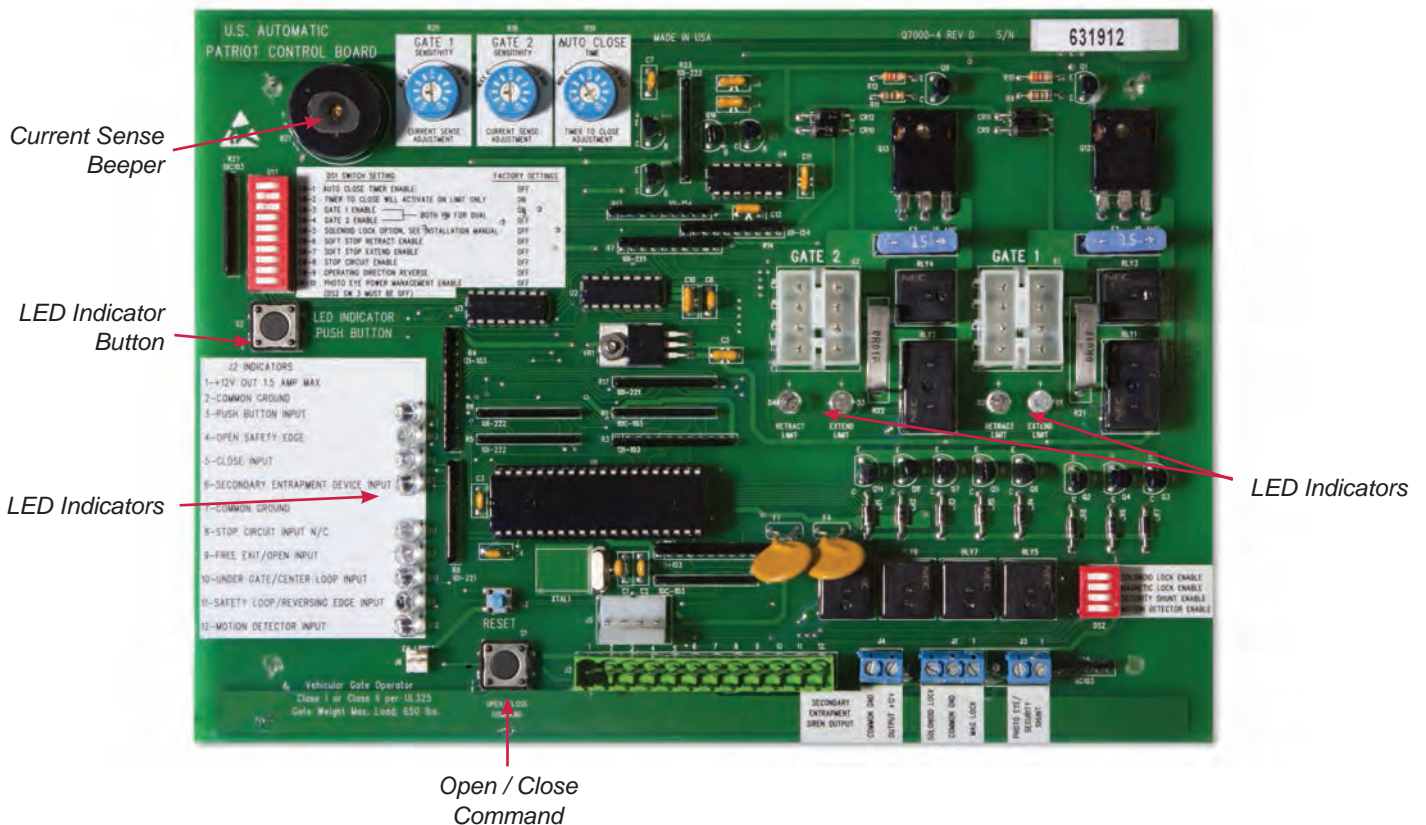

## Terms and Definitions

**LED** -Light Emitting Diode - small red lights on control board.

**Control board** - Located inside the control box in the upper right corner.

**Receiver** - Located inside the control box on the left side - coax cable connected to it.

**Remote/Transmitter** - Hand held unit with 2 buttons, used to operate the gate, sends signal to receiver when button is pressed.

**Linear Actuator** - Connected to gate and hinge post - contains the motor, gearbox limit switches and extension tube.

**Connector** - Control board has three types of connectors. Two white 8-pin connectors labeled Gate 1 and Gate 2 (X1 and X2) are used to connect actuator to control board, and one green 12-pin connector (J2) (located bottom center of control board) to connect radio receivers and accessories to control board. All three are plug type and can be disconnected (unplugged from control board) without disconnecting wires.

**Push Buttons** - Three are located on the control board. "Open / Close Command" used to operate the gate, "LED Indicator" used to activate the LED's and "Reset" used to reset the control board after current sensing twice before a limit is reached.

**Dip Switches** - Small switches, which are located on the control board in two places. The primary set DS1, is located in the upper left corner and the secondary set, DS2, is located in the lower right corner of the control board with functions listed beside each. See manual (page 32-33) for more information.

**Sensitivity adjustments** - Located on the control board (see page 34). These adjustments are the primary safety feature. If the gate comes in contact with an object it will stop and reverse. These adjustments control the amount of pressure applied to an object before reversing the gate.

**Charge Controller** - Located inside the control box in upper left corner (see page 24). This is the battery charger. The input power for this device can be either from a transformer or from a solar panel.

**Transformer** - This device connects to a 110 VAC electrical outlet and converts it to a low AC voltage that can be connected to the charge controller to provide continuous charging of the battery.

**Open and Close Limit** - This refers to the open or close stop position and are adjusted on the underside of the actuator.

**Entrapment Siren** - If the control board sensitivity circuit senses an obstruction it will reverse the gate and if a second obstruction is detected before the gate reaches a fully open or close limit the control board will shut down the operator and sound the entrapment alarm for five minutes or until the "Reset" button is pressed.

**Gate 2** - is defined as the 2nd gate on a dual gate system.

**Note: Never run the actuator while it is disconnected from the gate. Damage may occur. Always have the actuator connected during troubleshooting in case the operator starts working to prevent damaging internal components.**



## Summary of Symptoms Included in This Guide

1. Single gate will not operate.
2. Dual gate will not operate.
3. Single or Dual gate opens or closes slowly.
4. Gate will not automatically close.
5. Gate begins to open or close, but stops and reverses after a couple of seconds.
6. Single Gate opens correctly then closes immediately or single Gate closes correctly and then opens immediately.
7. Dual Gate opens correctly then closes immediately or dual Gate closes correctly then opens immediately.
8. Control board 15 amp fuse blows when "Open / Close Command" is given.
9. Transmitter (Remote control) will not operate the gate.
10. Photo eye, safety loop or other safety accessory will not reverse the gate when closing.
11. Pressing the "RESET" button only, causes the gate to operate.
12. Gate opens with the transmitter but will not close with the transmitter.
13. Gate only operates when the "LED INDICATOR" is pressed.
14. Charger / Charge Controller "External Power or Solar Power Light & Detection light are ON.
15. Gate Fully Open and Close Stop Positions are Changing (not consistent).
16. Battery (AC or Solar Charged) will not stay charged.
17. Charger / Charge Controller (Detection) Light is ON.

**1. My single gate will not operate: (Patriot I)**

1. Remove control box cover locate the "Open/Close Command" push button and press it to operate the gate.
2. Press the "Reset" push button located above the "Open/Close Command" button, then push the "Open/Close command" push button to operate the gate.
3. When pressing the "Open/Close Command" push button, listen for a clicking sound, if click is heard then verify:

The 15-amp fuse located on the control board is good if not replace it using the spare located on the control board. Also check the dipswitches (3 and 4) for correct switch settings based on where the actuator is connected to the control board (Gate 1 or Gate 2). If switches are correct and the fuse is good and clicking sound is heard, then the battery needs to be load tested to determine its condition. Charge or replace the battery depending on results.
4. Press and hold the "LED Indicator" push button and observe all of the red LED's

If the two limit LED's located below the actuator plug connector are both on the operator will not operate. You must adjust the limit switch

Example- if both limit LED's are on when the gate is in the closed position (and actuator is connected to the gate) the problem is with the retract limit switch. Adjust the retract limit until the LED goes off and continue to adjust until the gate is at the desired stopping position. Both LED's should never be on simultaneously.

  - a. If any of the LED's in the lower left corner of the control board are on then this must be corrected. These lights correspond to the J2 accessory inputs located at the bottom center of the control board.
  - b. Identify the light that comes ON and then the J2 pin number it is associated with.
  - c. Locate the accessory, which is connected to that J2 pin number
  - d. Disconnect the accessory wire from that J2 pin and verify gate operation.
5. Disconnect the green J2 connector. Once disconnected, press the "Open/Close Command" button.

If gate operates go to step 4 b above.
6. Verify that DS1 switch 8 is off.
7. Call the factory for more information if the above steps have not worked.



**2. My dual gate will not operate. (Patriot II)**

1. Follow steps 1 through 6 above.
2. Disconnect the actuator connectors plugged into the control board Gate 1 and Gate 2 (X1 and X2). Then locate the DS1 dipswitches on the control board. Turn off switch 4 (down on left side) and turn on switch 3 (down on the right side).  
  
Reconnect the connector from the actuator that goes to the gate closest to you. Connect it to the Gate 1 (X1) connector on the control board. Press the "Open/Close Command" button and verify that the gate operates.
3. If the gate operates correctly, disconnect the actuator plug and connect the other actuator plug into the Gate 1 (X1) connector. Press the "Open/Close Command" button and verify that the gate operates correctly. At this point you have tested each actuator individually. If both worked correctly in Gate 1 then go back to DS1 and turn switch 3 off and switch 4 on. Then repeat step 2 and 3 again using Gate 2 (X2) connector on control board in place of Gate 1 (X1).
4. If a problem is observed in steps 2 or 3 above most likely it was when the Gate 2 actuator (located the greatest distance from control box) was being tested. If this is correct check wiring splices for moisture, correct wiring etc. If the wiring is not in watertight conduit, this is most likely the problem. Tape is not watertight.



**3. My gate opens/  
closes slowly:**

**NOTE:** When the gate is running slow the reason is most likely low battery voltage. Two things need to be considered. Battery condition (replace or charge) and what caused the battery to become discharged. Bad motor in actuator is also possible but not common.

1. Determine which situation your operator falls into below:

**Solar charged:** If accessories are connected (keypads, loop detectors, any device powered by the battery) verify that the current draw needed to power them does not exceed the charging power of the solar panel. Verify that the charger is operating correctly; panel is facing a Southwestern direction and is not located in a shaded area. Inspect panel surface and wires for damage.

Test solar panel on a sunny day for correct voltage and current output. Remove solar panel plug from charge controller. Using a DC voltmeter, measure the dc voltage (should measure about 22 volts) and the dc current (should read about 300 ma) in the peak sun period. If either of these readings is incorrect the panel maybe defective please call the factory.

If none of the above check bad, then remove battery and have it load tested at a battery shop. Replace if bad.

**AC charged:** If accessories are connected (keypads, loop detectors, any device powered by the battery) verify that the current draw needed to power them does not exceed the charging power of the charger. Not likely on AC charged system. Verify that charger is working correctly and inspect charger and wires for damage.

**NOTE:** The USAutomatic charger does not output any voltage or current when disconnected from the battery. You cannot check charger by disconnecting from battery and measuring voltage output. To check charger refer to Charge controller operation check for details.

2. If none of the above check bad then remove battery and have it load tested at a battery shop. Replace if bad.



<p><b>4. My gate will not automatically close</b></p>	<p><b>NOTE:</b> If DS1 switch 1 is on and switch 2 is off then the gate should automatically close from any position. If switch 2 is also on the gate will only automatically close if the “Retract Limit” LED (both “open limit” LED’s for dual gate) is on.</p> <ol style="list-style-type: none"> <li>1. Locate the “Open/Close Command “ push button. Press the button to verify that the gate will close. If gate closes correctly then proceed to the steps below.</li> <li>2. Verify that DS1 switch 1 is on. If not, turn it on and recheck gate operation. If gate remains open, continue with step 3.</li> <li>3. If your installation is a single gate, then only DS1 switch 3 or 4 can be on. If both are on the gate will not automatically close. Turn off the one that is not being used and recheck gate operation.</li> <li>4. Locate the “LED Indicator” push button and depress and hold. While pushing the button observe the LED indicators located just below the Gate 1, Gate 2 (X1, X2) actuator plugs. Note which LED’s are on. Read note below.</li> </ol> <p><b>NOTE:</b> The two LED’s located below the Gate 1, Gate 2 actuator plug, when on, represent the closure of the limit switch. If the left LED is on, then the gate should be in the retracted position. If the LED on the right is on, then the gate should be in the extended position. If the LED for the retract position is not on when the actuator is fully retracted, then the auto close will not work. The limit switches need to be adjusted.</p> <ol style="list-style-type: none"> <li>5. Locate the “LED Indicator” push button and depress and hold. While pushing the button inspect the LED indicators located on the control board (lower left corner) and note which LED’s are on. If any LED’s are on disconnect the green J2 connector from the control board. Press the “Open/Close Command “ push button to close the gate. Press the button again to open the gate fully and verify the automatic close is working.</li> <li>6. If gate automatically closes correctly, then the accessory connected to the J2 connector that is activated (LED is on) needs to be repaired.</li> </ol>
<p><b>5. Gate begins to open or close but stops and reverses after a couple of seconds</b></p>	<ol style="list-style-type: none"> <li>1. Remove control box cover and locate the Patriot control board. Locate the sensitivity adjustment (see page 12) potentiometer located on the control board. The white center is adjustable and needs to be turned in a clockwise direction to increase force.</li> <li>2. Normally a setting of 5 will operate most gates; if your gate requires a setting above 8 there is a good chance that your gate has a problem, which needs to be corrected. Possible causes are incorrect hinges, gate touching the ground; gate not level or the actuator arm connected to the gate is bent. Identify and correct problem.</li> </ol>





<p><b>6. Single Gate opens or closes correctly, then immediately reverses direction.</b></p>	<ol style="list-style-type: none"> <li>1. This is most likely caused by an incorrect limit switch adjustment. The limit switch adjustments are located on the bottom of the actuator motor housing, behind the removable rubber plug. Locate the limit switch adjustment screws and determine which one needs to be adjusted (see page 39). Operate the gate. Once it reaches the desired retract or extend position, stop the gate in that position using the transmitter or “Open/Close Command” push button located on the Patriot control board.</li> <li>2. Locate the “LED Indicator” push button located on the left side of the Patriot control board. Also locate the retract and extend LED indicators below the actuator plug on the Patriot control board. The left LED represents the retract position and the right LED represents the extend position.</li> <li>3. With the gate in the desired open or close position, press and hold the “LED Indicator.” Observe which of the LED lights come on. If your actuator is in the desired retracted position, then the LED on the left should be on. If not adjust the retract limit switch (see page 39) until the LED comes on. If actuator was in the extend position adjust the extend limit switch until the close LED comes on.</li> <li>4. Once adjusted correctly the retract limit LED should be on when the actuator is retracted and the extend limit LED should be on when the actuator is extended.</li> <li>5. If the LED's will not come on contact the factory.</li> </ol>
<p><b>7. Dual Gate opens or closes correctly then immediately reverses direction.</b></p>	<ol style="list-style-type: none"> <li>1. This is most likely caused by an incorrect limit switch adjustment. First determine which gate is in need of adjustment.</li> <li>2. Locate the DS1 switches on the Patriot control board. Switch 3 and 4 should be turned on for a dual gate, turn off switch 4. This will disable one gate.</li> <li>3. Operate the gate and verify that it stops in the correct position. If so then turn switch 4 back on and turn switch 3 off. Operate the other gate now and verify that it stops in the correct position. One or both may not stop in the correct position.</li> <li>4. Once the gate that needs adjustment is identified (possibly both) refer to problem 6 above steps 1 through 5 for instructions.</li> </ol>



**8. Control board 15 amp fuse blows when Open/Close command is given.**

1. Fuses blow primarily for one reason, the gate cannot move. Causes might be something keeping the gate from moving, the gate is trying to move in the wrong direction due to incorrect limit switch setting or there might be a wiring problem. A wiring problem is most likely in a splice that might have been made during installation or it could be in the actuator housing.
2. Open the control box and locate the Patriot control board, locate the 2 LED's under the actuator connector on the control board. Press the "LED Indicator" push button and hold it in, observe the LED's and determine if the retract limit or extend limit LED is on. Then determine if the correct LED is on for the gate position. For example if the left LED is on that is the retract limit and the actuator should be in the retracted position. The right LED represents the extend limit position.
3. If the retract limit LED is on and the actuator is extended, a command to operate the gate will try to extend more, which can blow a fuse. If the extend limit LED is on and the actuator is retracted, a command to operate the gate will try to retract more, which can blow a fuse. In either case, the limit switches need to be adjusted and then the cause for them becoming misadjusted needs to be determined. The cause generally has to do with wiring; bad actuator plug connection at the Patriot control board or too much adjustment has been made during installation. Limit switches also get out of adjustment if the actuator runs while disconnected from the gate.
4. If a wiring problem is suspected, the orange, white and green wires are the ones to concentrate on. Check all splices and verify actuator connector is connected at the control board.
5. If the actuator is suspected of being bad either due to an internal wiring problem or a motor problem, call the factory for further troubleshooting and return information.



**9. Transmitter will not operate the gate.**  
*(LCR radio equipment only)*

1. Open the control box and locate the Patriot control board. Locate the "LED Indicator" push button and the "Push Button Input" LED. Push and hold the "LED indicator" push button, then press the transmitter button and observe the "Push Button Input" LED. The LED should come on while the transmitter button is depressed.
2. If the "Push Button Input" LED did not come on in step 1 then make sure that the green J2 connector on the control board is securely connected, replace the battery in the transmitter and verify that the transmitter is programmed to operate the receiver (refer to page 14 "programming receiver and transmitter").
3. If the "Push Button Input" LED in step 1 did come on and the gate did not operate then locate the "Open/Close Command" button located at the bottom center of the Patriot control board. Press the "Open/Close Command" button and note gate operation.
4. If the gate did not operate in step 3, verify the 15-amp fuse on the Patriot control board adjacent to the actuator plug being used is not blown, (a fuse can be blown and look good) replacing is the best way to verify fuse is good.
5. If the gate did not operate in step 3 and the fuse was good in step 4, most likely a safety accessory connected to the green J2 connector is active. Verify this by depressing the "LED Indicator" push button and observe the LED's located in the lower left corner of the Patriot control board. If an LED is on, identify the accessory connected to the corresponding J2 connector pin and correct the problem.
6. Other possibilities are: both the open and close limit LED's are on at the same time, adjust limit switches. Control board is defective or battery could be too weak to operate the gate. Please call the factory for help identifying the cause.



<p><b>10. Photo-eye, safety loop or other safety accessory will not reverse the gate when closing or hold the gate open</b></p>	<ol style="list-style-type: none"> <li>1. The first thing to check is the accessory wiring. The accessory needs power (+12 vdc) wired to battery positive terminal or to J2 pin 1 on the Patriot control board. It also needs ground, which can be wired to the battery or to J2 pin 2 or 7 on the Patriot control board. The other two connections are the “N/O (Normally Open) and Common ground”. The common ground can be connected to the battery or to J2 pin 2 or 7 on the Patriot control board. The N/O connection must be connected to J2 pin 11 “Safety Loop / Reversing Edge Input”. If the accessory is connected as described above it should reverse a closing gate or hold a gate open if the accessory is activated.</li> <li>2. To determine if the accessory is working correctly and that the Patriot control board is receiving the signal, locate the “LED Indicator” push button and the “Safety Loop / Reversing Edge Input” LED (located in the lower left corner of the Patriot control board).</li> <li>3. Press and hold the “LED indicator” push button and observe the “Safety Loop / Reversing Edge Input” LED. Activate the accessory in question (if photo-eye break the beam.) If the accessory is working properly, the LED light should come on when the device is activated. If the device does not turn on the LED light, check the wiring on the J2 connector and check J2 connector connection to the Patriot control board. If wiring is good, then the accessory is not operating correctly. Repair.</li> <li>4. If the “Safety Loop / Reversing Edge Input” LED comes on and the gate does not reverse direction when closing, call the factory for other possible causes and return information.</li> </ol>
<p><b>11. Pressing the “RESET” button only, causes the gate to operate</b></p>	<ol style="list-style-type: none"> <li>1. This problem is probably due to a bad receiver. First locate the “LED Indicator” push button on the Patriot control board. Then locate the “Push Button Input” LED located in the lower left corner of the Patriot control board.</li> <li>2. Press the “LED Indicator” button and observe the “Push Button Input” LED. If the LED comes on then the receiver relay is stuck closed and needs to be repaired or replaced.</li> <li>3. If the “Push Button Input” LED does not come on, call the factory for further troubleshooting and return information.</li> </ol>



<p><b>12. Gate opens using transmitter, but will not close using transmitter.</b> <i>(LCR receiver only)</i></p>	<ol style="list-style-type: none"> <li>1. The problem is most likely the programming of the LCR receiver (P2 relay is programmed to latch mode)</li> <li>2. On the Patriot control board locate press and hold the “LED Indicator” pushbutton.</li> <li>3. Look in the lower left corner of the Patriot control board and note any LED’s that are on.</li> <li>4. If the “Free Exit/Open Input” is on then the receiver (P2) is programmed to latch mode.</li> <li>5. Go to page 14 “Resetting receiver P2 relay to momentary mode”</li> <li>6. If this does not correct the problem return to troubleshooting section 4 and perform steps 1-6.</li> <li>7. If problem is not corrected, call the factory for further troubleshooting.</li> </ol>
<p><b>13. Gate only operates when the “LED INDICATOR” is pressed.</b></p>	<ol style="list-style-type: none"> <li>1. An accessory wiring problem or a bad control board can cause this, this problem can be intermittent and possibly take a little patience in locating the problem.</li> <li>2. Verify that the problem exist when using the “Open /Close Command” on the control board. Press the “Open/Close Command” push button and verify gate will not operate.</li> <li>3. Press the “Led Indicator” on the control board and hold then press the “Open/Close Command” push button on the control board. If the gate operates proceed to step 4.</li> <li>4. Remove the J2 accessory-wiring plug from the control board. This connector can be disconnected from the control board by placing a finger under the plug and pulling to remove.</li> <li>5. Press the “Open/Close Command” push button and verify gate operation. If gate operates then reconnect the J2 connector and verify gate operation using the “Open/Close Command” push button. If gate fails to operate when the J2 connector is reconnected then the problem is most likely in the accessory wiring. Most likely a bad ground connection on the accessory verify all wiring on the accessories connected to the J2 connector.</li> <li>6. If gate fails to operate when the J2 connector is disconnected then the control board is most likely the problem. Please contact the factory for further troubleshooting options.</li> </ol> <p><b>NOTE:</b> Keep in mind that this is an intermittent problem and it might be necessary to try this a few times to verify the problem.</p>



<p><b>14. Charger / Charge controller “External Power or Solar Power Light &amp; Detection Light are ON.</b></p>	<ol style="list-style-type: none"> <li>1. This indicated that the battery is not connected to the charger / charge controller.</li> <li>2. Verify that the 2 wire harness going to the battery is connected to the battery and also connected to the charger / charge controller.</li> </ol>
<p><b>15. Gate Fully Open and Close Stop Positions are Changing (not consistent).</b></p>	<p><b>NOTE:</b> Verify that the open and close positions are both changing randomly, before following these steps.</p> <ol style="list-style-type: none"> <li>1. Remove the five 5/16 bolts from the back of the actuator to expose the limit assembly.</li> <li>2. Loosen the 4 screws that hold the limit assembly in place (see below)</li> <li>3. Gently push the limit assembly over reducing the spacing between the small white gear and the blue gear (see below)</li> <li>4. While holding the limit assembly in place tighten the 4 screws.</li> <li>5. Reinstall the rear housing and adjust retract and extend limits to desired stop positions.</li> </ol>

Top of Actuator

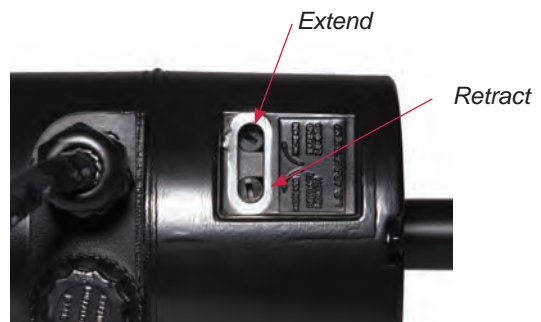
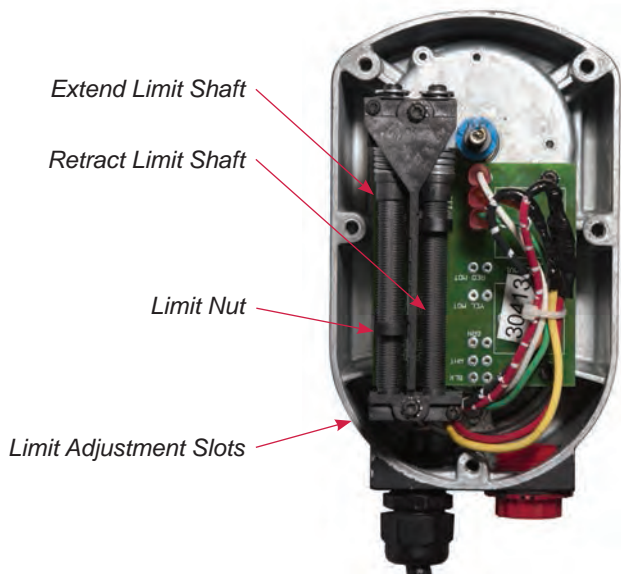

Bottom view of Actuator w/plug removed

**16. Battery (AC or Solar Charged) will not stay charged**

1. The most common reason for this type of problem is a bad battery. It is highly recommended that the battery be load tested at a battery store to verify that it is good. The load test is the only sure way to know if we have a good battery.
2. If the battery load test good then other items need to be checked such as system design, installation or possible charging problems with the system charger / charge controller.

**System design and Installation**

1. Verify the solar panel is facing in a South to Southwest direction and that the panel surface is not shaded by some object.
2. System design refers to the accessories connected to the system. Accessories connected to the system cannot use more energy than the charging system can provide. Not all accessories are created equally and some manufacturers use much more energy than others to perform the same function. These concerns are minimized in an AC charged system where the charger has power connected to it continually.

**AC Charged Systems ONLY**

- A. If your system is equipped with the USAutomatic charger / charge controller part # 520007 and is AC charged (not solar) verify the charger / charge controller is properly working. The "external Power" light should be ON and either the "Charging or Charged" light should be ON.
- B. If the "external power" light is not ON then check the 120 VAC outlet the transformer is plugged into for the correct voltage and correct problem if necessary.
- C. If the 120 VAC power checks good then disconnect the transformer from the charger / charge controller "Power In" plug and using a volt meter check the transformer output. The transformer should read about 18 VAC, if the transformer output is incorrect the transformer needs to be replaced with USAutomatic part # 520008.

**Solar Charged Systems ONLY**

1. If your system is equipped with the USAutomatic charger / charge controller part # 520007 and is solar charged (not AC) verify the charger / charge controller is properly working. The "Solar Power" light should be ON and either the "Charging or Charged" light should be ON. This can only be verified when the sun is directly on the solar panel.
2. If the "solar power" light is not ON then using a voltmeter check the output of the solar panel for the proper voltage.

*(continued on next page)*



	<p>3. Remove the solar panel plug from the charger / charge controller “power In” plug and measure the DC voltage from the solar panel it typically should be about 19 to 22 VDC. This reading must be taken when the skies are clear and the sun is up directly on the panel.</p> <p><b>NOTE:</b> This reading does not guarantee the solar panel is outputting the correct current to keep the battery charged, but it is a good first check.</p> <p>4. If the solar panel DC voltage checks good and the “solar power” light does not come ON when connected to the charger / charge controller then it is bad, replace with USAutomatic part # 520007.</p>
<p><b>17. Charger / Charge Controller “Detection” Light is ON</b></p>	<ol style="list-style-type: none"> <li>1. Battery is not connected to the charger / charge controller.</li> <li>2. Check wiring harness connection to the charger / charge controller</li> <li>3. Check wiring harness connection to the battery terminals.</li> </ol>







# Appendix

## A The Patriot Solar Charged System

The solar option allows you to install the gate operator in remote areas or in applications where you prefer to be solar charged. Solar charging provides isolation from lightning that might damage the unit via the AC power needed for the transformer.

The Patriot gate operator is designed to provide enough cycles a day for most installations without needing more than one solar panel. Care must be taken to ensure the solar panel has full sun throughout the day; partial sun will give partial results. If no sun is present then a solar system is not practical no matter how many panels might be installed. Solar Panel must be kept clean and in full sunlight.

The design of the system must pay particular attention to any accessories that might be added, use only Solar Friendly accessories to help avoid premature battery failure. For a complete list of accessories please visit [www.usautomatic.com](http://www.usautomatic.com).

### GATE CYCLES PER DAY SOLAR CHARGED SYSTEM (Optional Solar Kit PN #520025)

Solar charged systems should not exceed the cycles listed in the chart below. These numbers are based on a single 6 watt solar panel installation. If additional panels are installed additional cycles will be available.

Model Type	REGION 1	REGION 2	REGION 3
Patriot I Single Gate	22 cycles per day	36 cycles per day	65 cycles per day
Patriot II Dual Gate	11 cycles per day	18 cycles per day	32 cycles per day

Region 1 covers the area of the country receiving the least amount of solar radiation. On average the amount of charge time is 2.5 hours in region 1, 3.5 hours in region 2 and 5.5 hours in region 3.

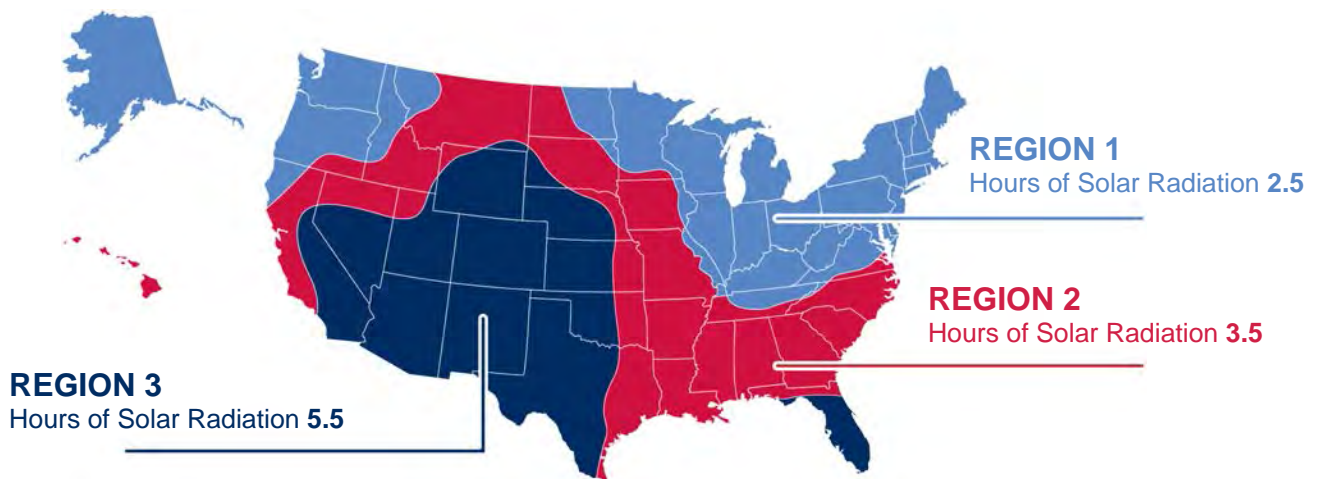

These are conservative numbers and the Patriot operator should have no problem performing as stated in the chart above. See Region Map above to determine cycles that can be expected. These numbers are based on a basic system with the standard 6 watt solar panel. Adding solar friendly accessories will not have any great affect on the numbers stated. Using other accessories can cause premature battery failure.

## **B** Extending Charge Device Location (AC or Solar)

If charge device cable needs to be extended to reach the charge controller use "Patriot Charge Cable Extension Pigtails" Part Number 630038 (see figure). These DC plug pigtails connect to each end of a customer provided extension cable. Connections should be made in customer provided water tight box. Use charts below to determine wire size needed for the distance to be extended. The cable must be a 2 conductor cable, stranded wire recommended.



**Do not modify the transformer or solar panel cable, this will void the product warranty.**

1. Splice mate for the charge controller to cable end located in control box.
2. Splice mate for the charge device to cable end that connects to charge device.  
A water tight junction box should be used to keep connections dry.
3. Install DC plug connection and splice into junction box.



<b>Charge Cable Extension Cable Selection Chart</b>				
Transformer Extension Wire Size Chart				
0 to 100 ft	101 to 250 ft	251 to 500 ft	501 to 750 ft	750 to 1000 ft
18 gauge wire	16 gauge wire	14 gauge wire	12 gauge wire	10 gauge wire
Solar Extension Wire Size Chart				
	15 to 100 feet	100 to 250 feet	250 to 500 feet	
	18 gauge wire	16 gauge wire	14 gauge wire	

The wire used must be rated for Direct Burial use, unless in conduit. Wire ran in conduit must be rated for outdoor use. The above Table lists the recommended wire gauge per application length. Using a smaller gauge may impede performance or cause system to malfunction

# C

## CHARGE CONTROLLER

### L.E.D. DESCRIPTIONS

**EXTERNAL POWER ADAPTOR** - Illuminates continuously while power from A.C. Power Supply Adaptor is sensed.

**SOLAR PANEL** - Illuminates continuously while power from Solar Panel is sensed.

**DETECTION** - If illuminated for longer than 3 seconds check connection on battery.

**CHARGING** - Continuous or flashing indicates charging – refer to Charge Algorithm Section, for further details.

**CHARGED** - On continuously when input power is present and battery fully charged. Flashes when battery capacity is low.

**SYSTEM ERROR** - If flashing, the charger has entered Failure Mode. Disconnecting power will reset charger, but if source of failure is not corrected, Failure Mode will occur again.- refer to the following Table to Decode the Error Type:

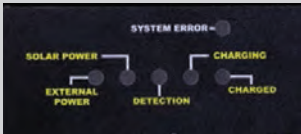
	L.E.D.s (First 4 L.E.D.s from Left)			
	1st	2nd	3rd	4th
<b>Wrong Battery Voltage</b>	Off	Off	Off	Flash
<b>Reverse Battery Connection</b>	Off	Off	Flash	Off
<b>Thermal Runaway Condition</b>	Off	Flash	Off	Off
<b>Charge Time Monitor - 1</b>	Off	Flash	Flash	Off
<b>Charge Time Monitor - 2</b>	Off	Flash	Flash	Flash
<b>Excessive Battery Drain</b>	Flash	Off	Off	Off
<b>Failed Pre-Qualification Test -1</b>	Flash	Off	Off	Flash
<b>Failed Pre-Qualification Test -2</b>	Flash	Off	Flash	Off

## POSSIBLE REMEDIES TO CHARGE CONTROLLER 'FAILURES'

<b>WRONG BATTERY VOLTAGE</b>	Charger connected to a 24v battery. Reconnect to a battery rated at 12Vdc.
<b>REVERSE BATTERY CONNECTION</b>	Check and correct any reverse battery.
<b>THERMAL RUNAWAY CONDITION</b>	Old Battery - cells, inside battery, age differently. During charging, and over the course of many years of operation, OR, many battery discharges to levels beyond 100% discharged, this error may occur and the battery(s) may have to be replaced.
<b>CHARGE TIME MONITOR – 1 and 2</b>	<p>Battery pack took too long to complete its charge. Possible causes include a load (gate cycling repeatedly for a long period of time) during charging or the battery pack is too large (Many batteries connected in a parallel circuit). Apply the following formula to determine if the Timer may run out due to a large battery:</p> $\text{Charge Time} = \frac{\text{Battery Capacity (AH)}}{2} \times 1.25$ <p><b>Calculated Charge Time must be less than approximately 108hrs.</b></p> <p>Output Amps and Battery Capacity (AH - Ampere-hour) are listed on your battery or contact your battery purchasing source.</p> <p>Example: Charge time to for a fully discharged 36 AH battery:  <math>36\text{AH} / 2 \text{ Amps} \times 1.25 = 22.5 \text{ Hrs} - \text{ok to use.}</math></p>
<b>EXCESSIVE BATTERY DRAIN</b>	Excessively high number of cycles discharging the battery beyond point of no return. Stop gate, and allow battery time to recharge.
<b>PRE-QUALIFICATION TEST - 1 and 2</b>	During Battery testing, if a battery was previously allowed to discharge to a very low voltage, such as 1 or 2Vdc, the charger puts a low current through the battery to try to get the battery to come back to life. The battery may be taking too long to come back.
<b>NO POWER ON CHARGER</b>	Check the transformer Supply Adaptor Plug-in, or the Solar Panel for proper connection.



# Patriot Swing Gate Operator

## LIMITED WARRANTY

USA Automatic, LTD warrants this product to be free of defects in materials for a period of 3 YEARS following purchase USAUTOMATIC, LTD will repair or replace the product free of charge, including parts, shop labor, return shipping and handling.

The Patriot control board warranty is for a period of 5 years. It does not cover damage caused by weather, natural disasters or severe acid damage from a battery.

### CONSUMER AFTER INSTALL:

If you have operation questions or are in need of warranty service, please contact our Product Support department by email at [www.usautomatic.com](http://www.usautomatic.com) or call 888-204-0174 Monday-Friday. If the issue is not resolvable, a manufacturer's warranty repair order may be issued. To have the product(s) sent for warranty service, a Return Authorization number (RA#) will be issued which must be written on the outside of the package. Packages without RA # may not be accepted. Packages for warranty service may be sent to the address below.

All repairs or replacements are at the discretion of the Manufacturer. This warranty excludes items that have been abused, altered, incorrectly installed, and damaged by weather or other acts of God. Changes or modifications not expressly approved by the Manufacturer could void the warranty. This warranty is limited to the product only. No consequential damages are covered.

USA Automatic, LTD  
118 Hillside Drive  
Lewisville, Tx 75057  
866-711-0001

***Keep this information for your records***

Model: \_\_\_\_\_ Serial Number\*: \_\_\_\_\_

Date of Purchase: \_\_\_\_ / \_\_\_\_ / \_\_\_\_ Purchased from: \_\_\_\_\_

*\*Serial number can be found by opening cover and looking on the control board.*





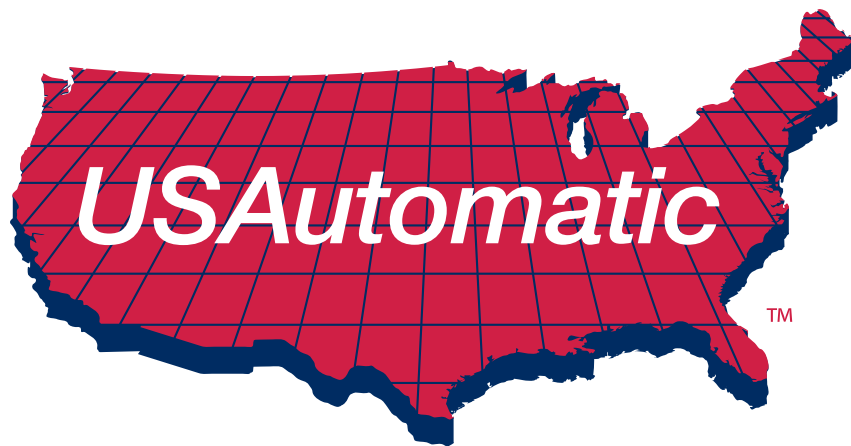

© USAAutomatic, LTD, 2015 rev. A

*All rights reserved. No part of this may be reproduced by any means without the expressed written consent of the publisher.*



**PROUDLY MADE IN THE USA**

